

Name _____

Determine if the ordered pair satisfies the inequality.

1) $x + y > 4$: $(-5, 10)$

2) $x - y \leq -2$: $(-4, 2)$

3) $x - y \leq 8$: $(2, -9)$

4) $2x + 3y \leq 6$: $(3, 2)$

5) $x + 2y > 3$: $(3, 2)$

6) $x + 2y < -3$: $(6, -4)$

7) $y > -x - 1$: $(-4, 4)$

8) $x \leq y - 4$: $(5, 6)$

Graph the inequality.

9) $x - y > -3$

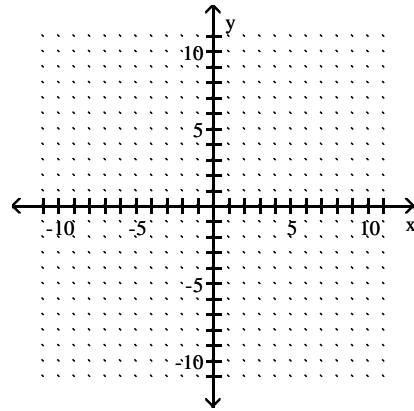

10) $x + y < -4$

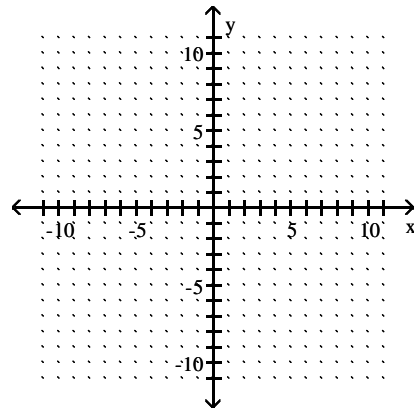

11) $x + y \leq 6$

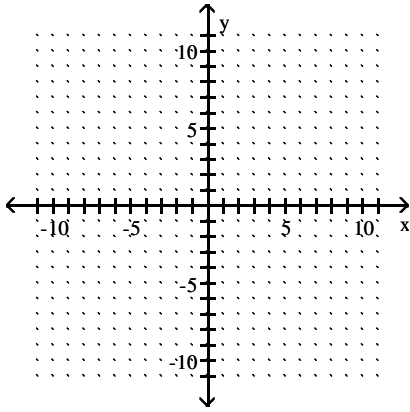

14) $-3x + y \leq 3$

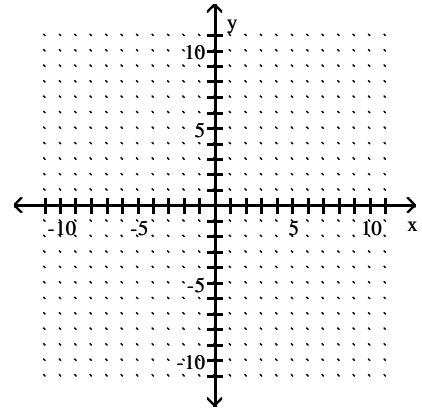

12) $2x + y \leq -6$

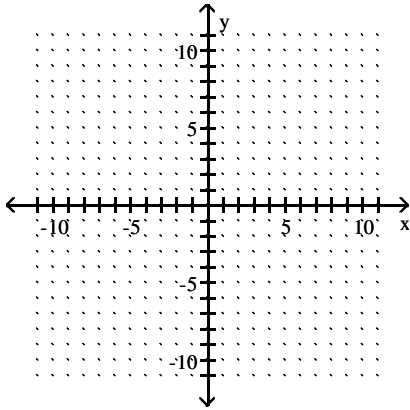

15) $2x + 5y \leq 10$

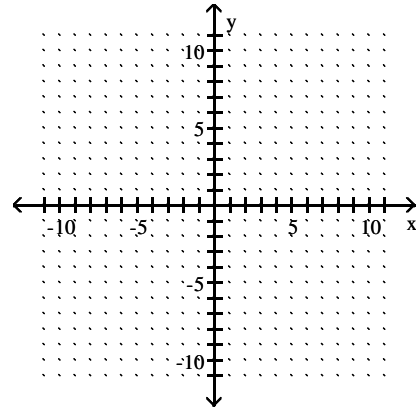

13) $x + 3y \geq 5$

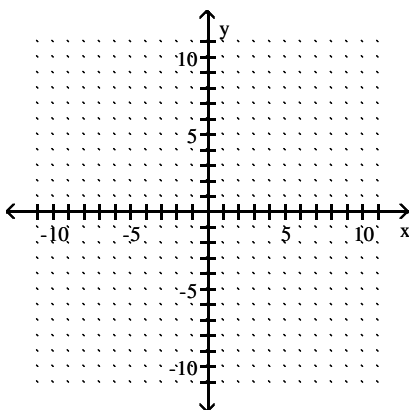

16) $-2x - 5y \leq 10$

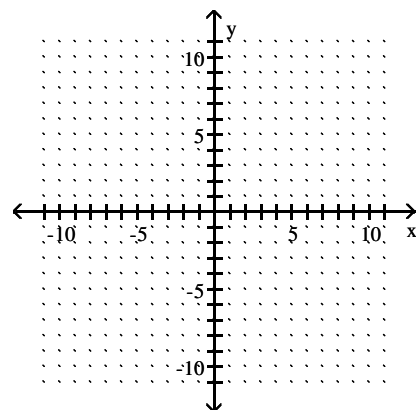

17) $3x + 5y \geq -15$

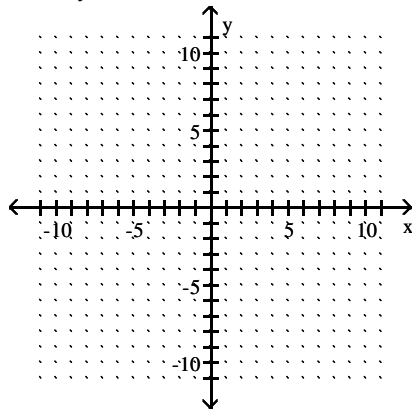

20) $y \leq -2x - 3$

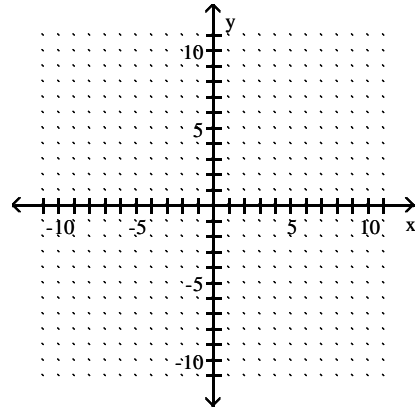

18) $y \geq 3x$

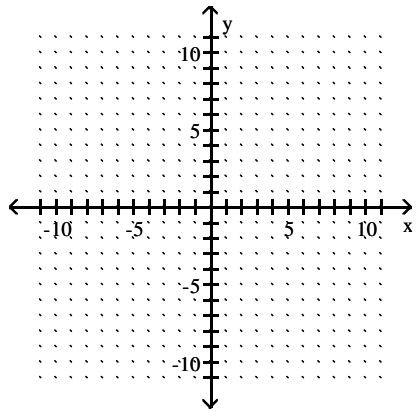

21) $y > 5x - 9$

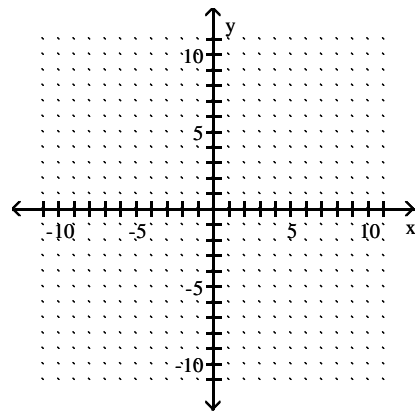

19) $y < \frac{5}{2}x$

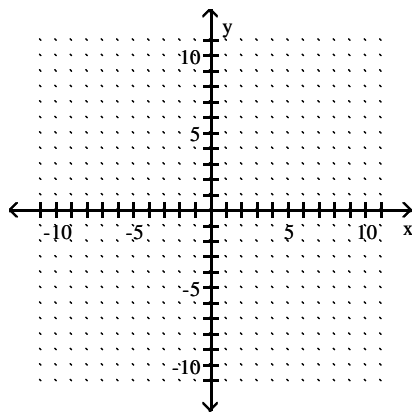

22) $x > 6$

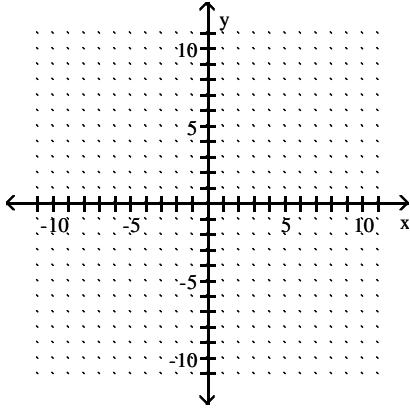

23) $y \leq -9$

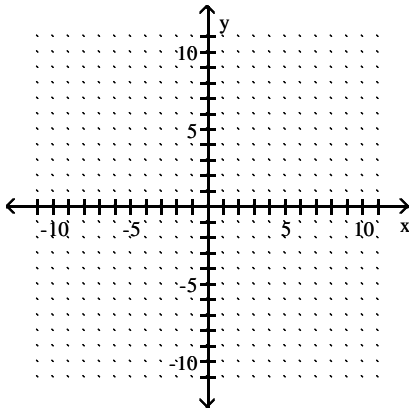

Graph the linear inequality described by the sentence.

24) The sum of the x-variable and the y-variable is at least -4 .

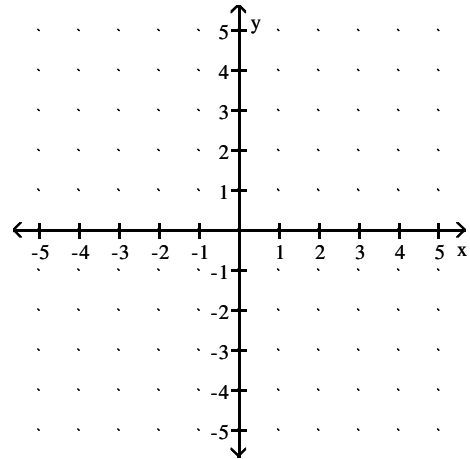

25) The sum of 2 times the x-variable and 4 times the y-variable is at most 8.

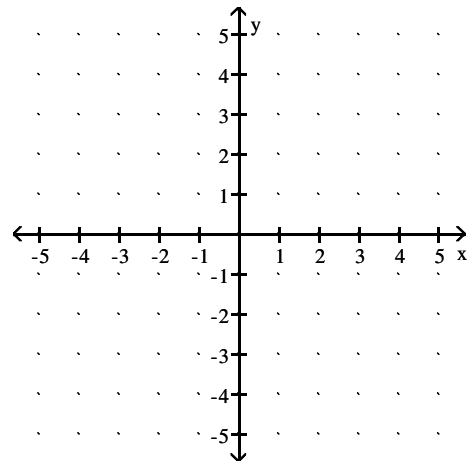

Solve.

- 26) A furniture company manufactures chairs and tables. Each chair requires 2 labor-hours to manufacture. Each table requires 4 labor-hours to manufacture. The company has 40 labor-hours available per day. These data are summarized by the linear inequality $2x + 4y \leq 40$. Graph an inequality that describes when the labor-hours for making x chairs and y tables will not exceed the number of labor-hours the company has available.

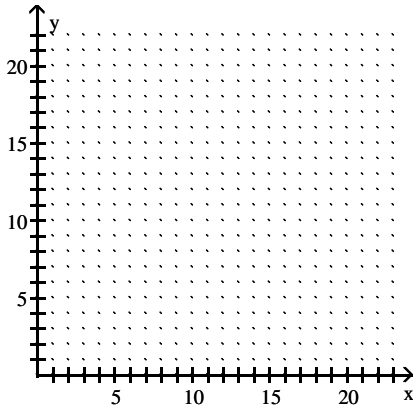

- 27) A man has \$4.00 and wants to buy pretzels and soda from a vender. The pretzels cost \$0.50 per bag and the soda cost \$1.00 per cup. These data are summarized by the linear inequality $0.50x + 1.00y \leq 4.00$. Graph an inequality that describes when the cost of x bags of pretzels and y cups of soda does not exceed the amount of money the man has to spend.

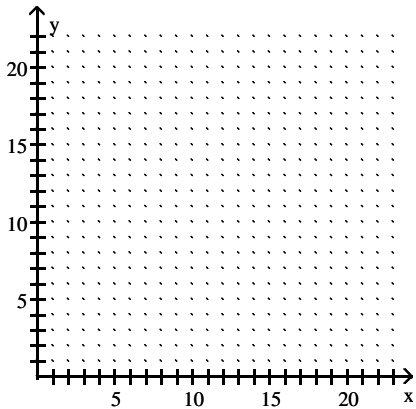

- 28) A delivery company has two sizes of boxes to ship. Their small box has a volume of 5 cubic feet and their large box has a volume of 15 cubic feet. Each of the company's trucks can carry 150 cubic feet of cargo. These data are summarized by the linear inequality $5x + 15y \leq 150$. Graph an inequality that describes when the volumes of x small boxes and y large does not exceed the volume of a truck.

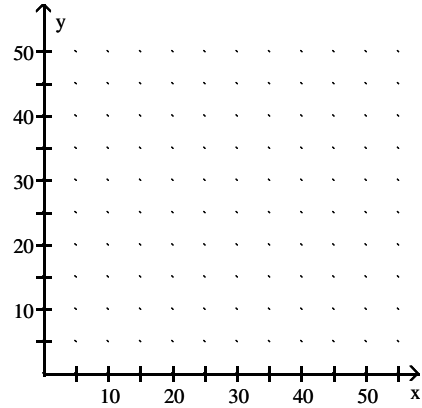

- 29) A woman works out by running and swimming. When she runs, she burns 7 calories per minute. When she swims, she burns 8 calories per minute. She wants to burn at least 392 calories in her workout. These data are summarized by the linear inequality $7x + 8y \geq 392$. Graph an inequality that describes when x minutes running and y minutes swimming will burn at least as many calories as the woman wants to burn.

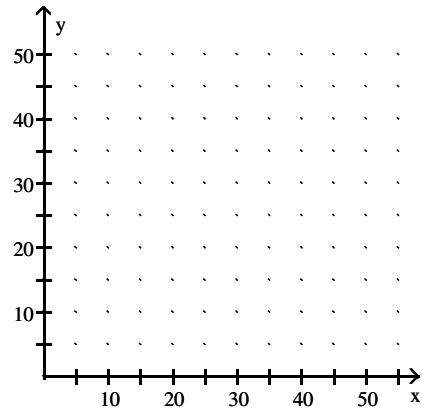

Answer Key

Testname: 04.6V02

- 1) Yes
- 2) Yes
- 3) No
- 4) No
- 5) Yes
- 6) No
- 7) Yes
- 8) No
- 9)

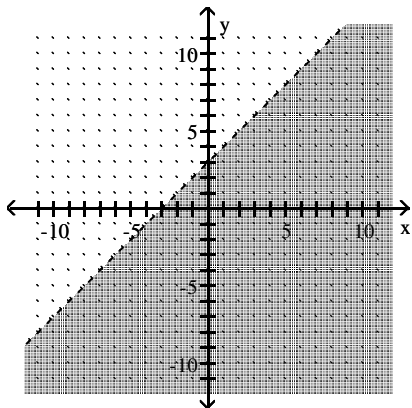

10)

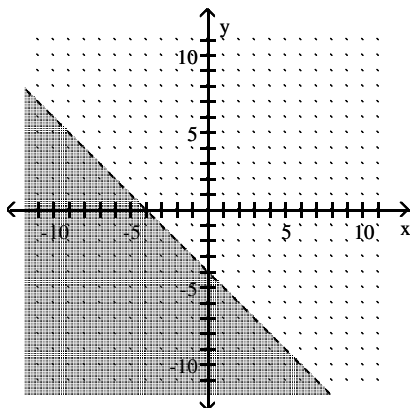

11)

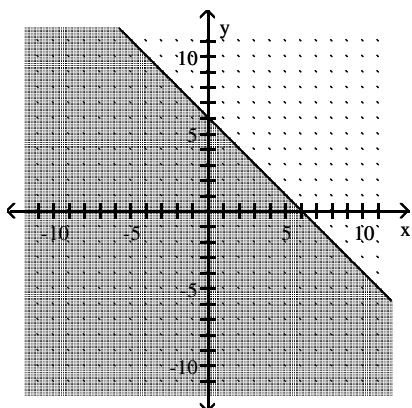

Answer Key
Testname: 04.6V02

12)

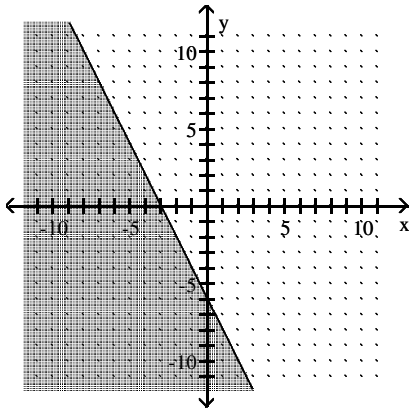

13)

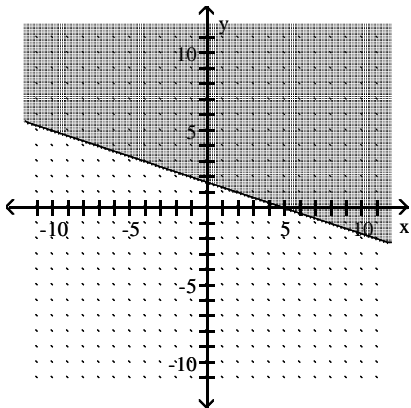

14)

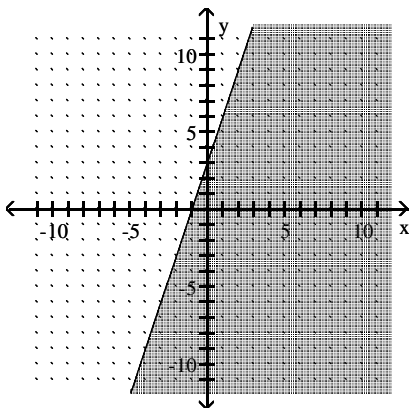

Answer Key
Testname: 04.6V02

15)

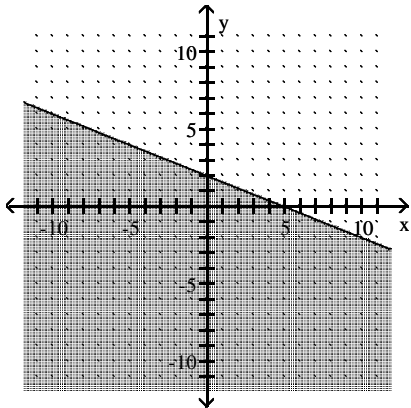

16)

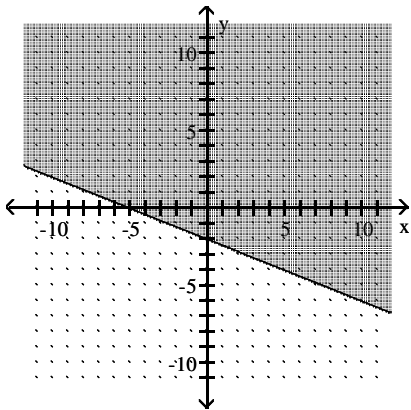

17)

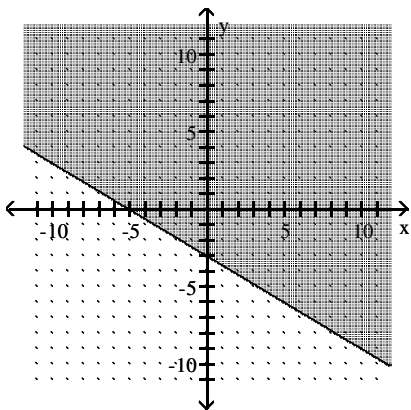

Answer Key
Testname: 04.6V02

18)

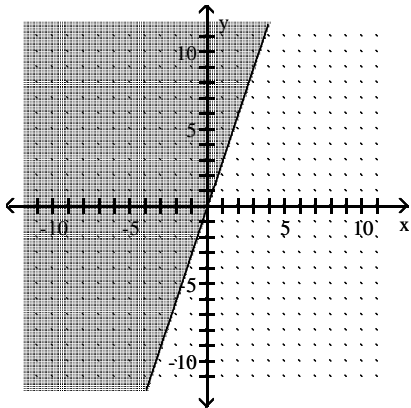

19)

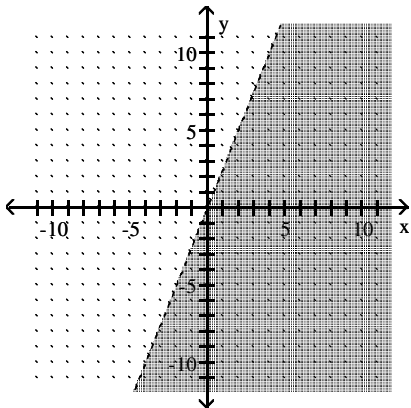

20)

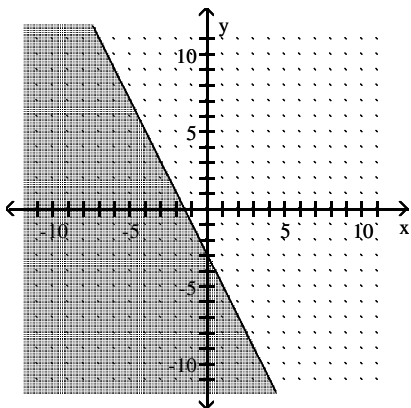

Answer Key
Testname: 04.6V02

21)

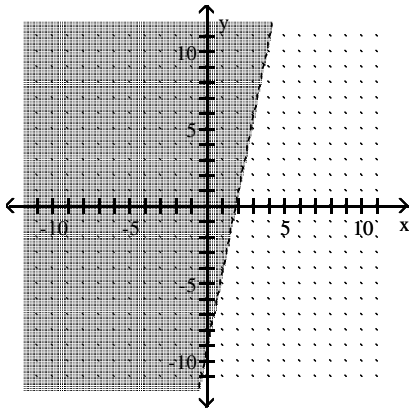

22)

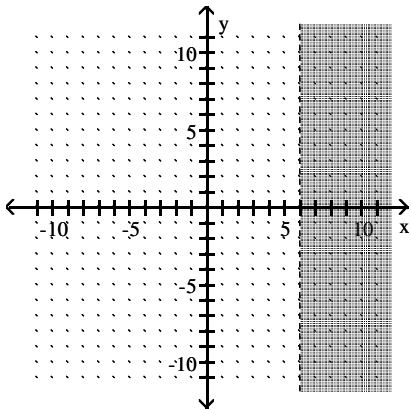

23)

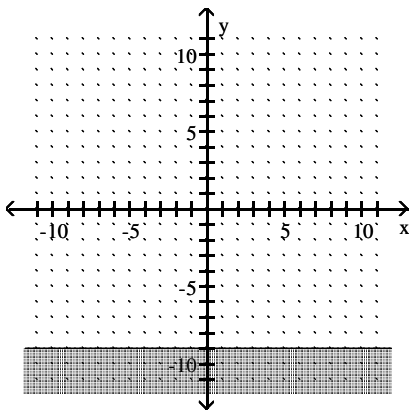

Answer Key
Testname: 04.6V02

24)

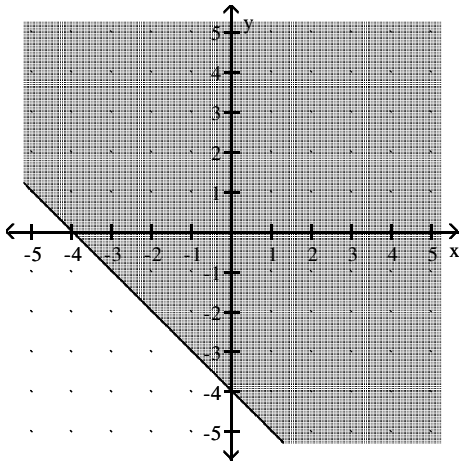

25)

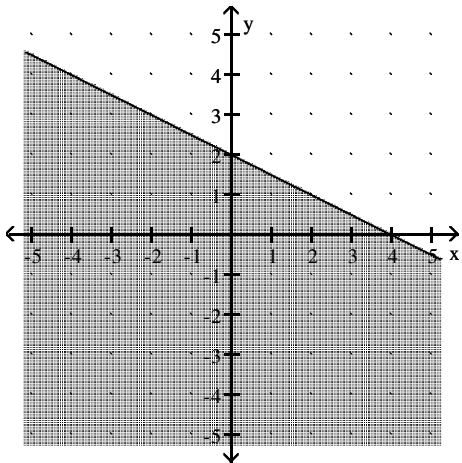

26)

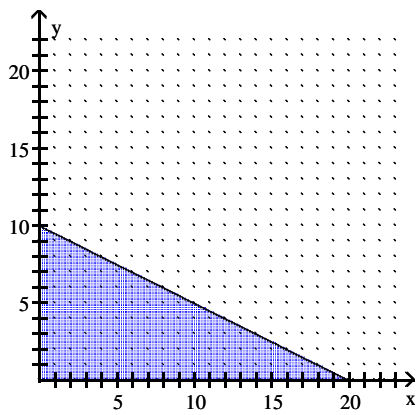

Answer Key
Testname: 04.6V02

27)

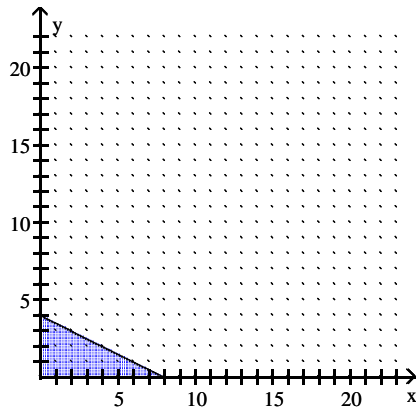

28)

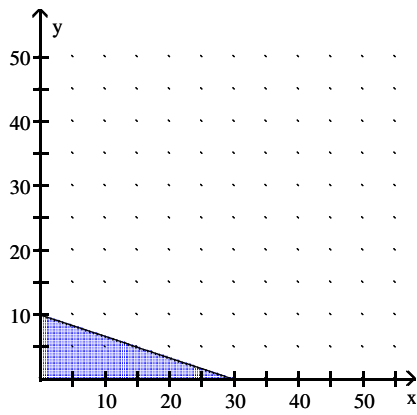

29)

