

Name _____

Rewrite the expression with a positive rational exponent. Simplify, if possible.

1) $\left(\frac{8a^3b^{-6}}{a^{-3}b^6}\right)^{1/3}$

1) _____

2) $\left(\frac{9a^2b^{-4}}{a^{-2}b^4}\right)^{1/2}$

2) _____

3) $\left(\frac{16a^2b^{-4}}{a^{-2}b^4}\right)^{1/2}$

3) _____

4) $\left(\frac{4a^2b^{-4}}{a^{-2}b^4}\right)^{1/2}$

4) _____

5) $\left(\frac{27a^3b^{-6}}{a^{-3}b^6}\right)^{1/3}$

5) _____

6) $\left(\frac{64a^3b^{-6}}{a^{-3}b^6}\right)^{1/3}$

6) _____

Rationalize the denominator and simplify. Assume that all variables represent positive real numbers.

7) $\frac{\sqrt{2} - \sqrt{3}}{\sqrt{2} + \sqrt{3}}$

7) _____

8) $\frac{\sqrt{6} - \sqrt{7}}{\sqrt{6} + \sqrt{7}}$

8) _____

9) $\frac{x - 100}{\sqrt{x} + 10}$

9) _____

10) $\frac{\sqrt{x} - 5}{\sqrt{x} + 5}$

10) _____

11) $\frac{\sqrt{x} + 11}{\sqrt{x} - 11}$

11) _____

12) $\frac{\sqrt{x} - 1}{\sqrt{x} + 1}$

12) _____

Solve the equation.

13) $\sqrt{5y + 2} = \sqrt{2y - 8}$

13) _____

14) $\sqrt{5y - 5} = \sqrt{3y - 8}$

14) _____

$$15) \sqrt[3]{8-8x} + \sqrt[3]{6-4x} = 0$$

15) _____

$$16) \sqrt[3]{-8-4x} - \sqrt[3]{7+2x} = 0$$

16) _____

$$17) \sqrt{2x+5} - \sqrt{x-2} = 3$$

17) _____

$$18) \sqrt{x^2} = \sqrt{x+12}$$

18) _____

$$19) \sqrt{x^2+44} = 2\sqrt{4x-1}$$

19) _____

$$20) \sqrt{x^2+28} = 2\sqrt{3x-1}$$

20) _____

$$21) \sqrt{x^2+28} = 2\sqrt{3x-1}$$

21) _____

1. Graph the function.

2. Using Interval Notation, express the Domain and Range of the function.

22) $f(x) = \sqrt{x + 3}$

22) _____

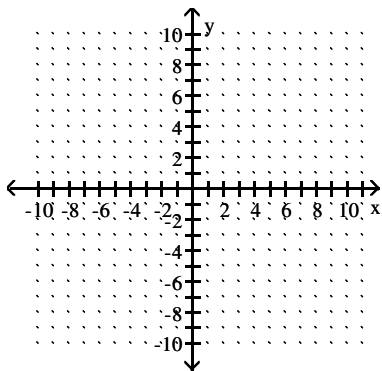

Determine the domain and range of the function. Then graph it.

23) $f(x) = \sqrt{x + 4}$

23) _____

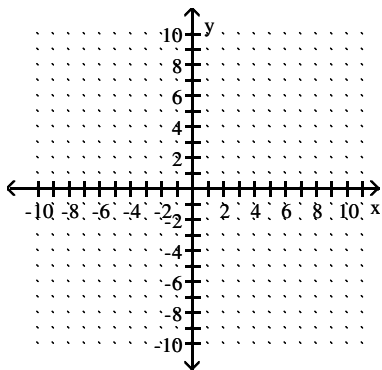

24) $f(x) = \sqrt{x - 3}$

24) _____

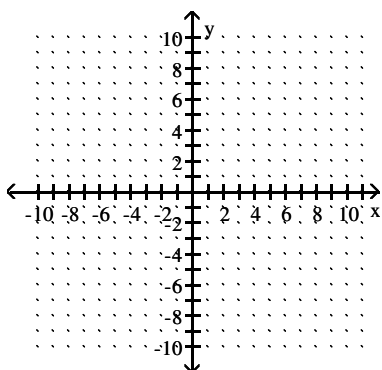

25) $f(x) = \sqrt{x - 2}$

25) _____

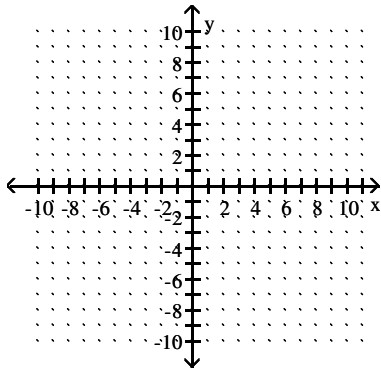

26) $f(x) = \sqrt{x} - 1$

26) _____

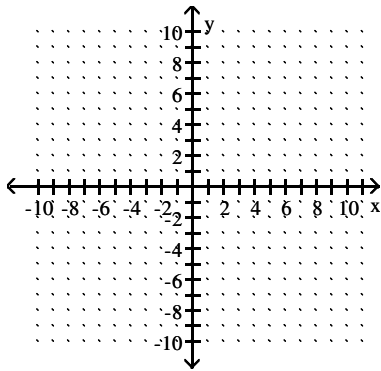

27) $f(x) = \sqrt{x} + 3$

27) _____

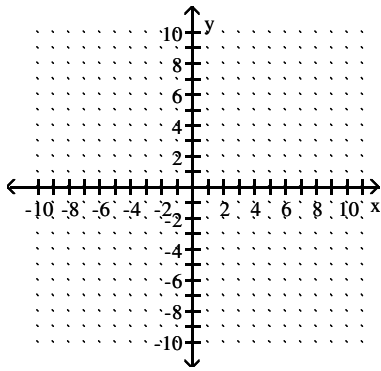

28) $f(x) = \sqrt{x} - 2$

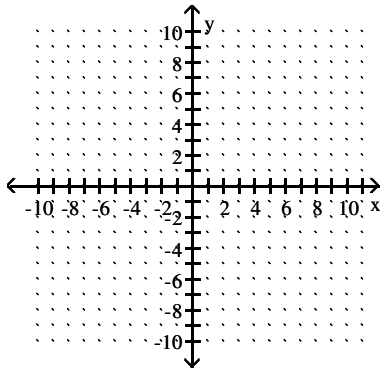

28) _____

29) $f(x) = \sqrt{x} + 2$

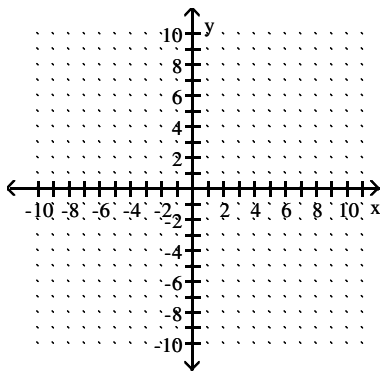

29) _____

30) $f(x) = \sqrt{x} + 4$

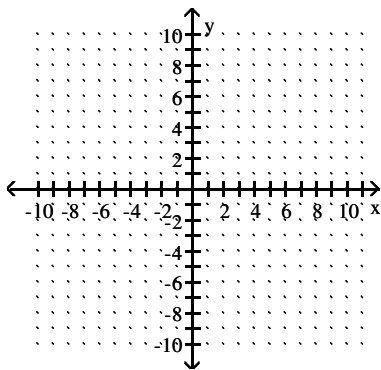

30) _____

Write the expression as a pure imaginary number.

31) $\sqrt{-25}$

31) _____

$32) \sqrt{-4}$

32) _____

$33) \sqrt{-324}$

33) _____

$34) \sqrt{-196}$

34) _____

$35) \sqrt{-169}$

35) _____

$36) \sqrt{-289}$

36) _____

$37) \sqrt{-64}$

37) _____

$38) \sqrt{-81}$

38) _____

Simplify.

$39) i^{52}$

39) _____

$40) i^{32}$

40) _____

41) i^{16}

41) _____

42) i^{44}

42) _____

43) i^{33}

43) _____

44) i^{45}

44) _____

45) i^{30}

45) _____

Solve the equation by the square root property. If possible, simplify radicals or rationalize denominators. Express imaginary solutions in the form $a + bi$.

46) $\left(x - \frac{3}{2}\right)^2 = \frac{121}{4}$

46) _____

47) $\left(x - \frac{3}{2}\right)^2 = \frac{9}{4}$

47) _____

48) $\left(x + \frac{3}{4}\right)^2 = \frac{6}{16}$

48) _____

$$49) \left(x + \frac{5}{4}\right)^2 = \frac{7}{16}$$

49) _____

$$50) \left(x - \frac{5}{2}\right)^2 = \frac{49}{4}$$

50) _____

$$51) \left(x - \frac{1}{2}\right)^2 = \frac{25}{4}$$

51) _____

$$52) \left(x - \frac{3}{2}\right)^2 = \frac{81}{4}$$

52) _____

$$53) (x - 2)^2 = -121$$

53) _____

$$54) (x - 7)^2 = -25$$

54) _____

$$55) (x - 7)^2 = -9$$

55) _____

$$56) (x - 10)^2 = -49$$

56) _____

$$57) (x - 11)^2 = -144$$

57) _____

58) $(x - 11)^2 = -9$

58) _____

59) $(x - 2)^2 = -81$

59) _____

60) $(x - 11)^2 = -36$

60) _____

Solve the problem.

61) The revenue for a small company is given by the quadratic function $r(t) = 12t^2 + 7t + 970$ where t is the number of years since 1998 and $r(t)$ is in thousands of dollars. If this trend continues, find the year after 1998 in which the company's revenue will be \$2499 thousand. Round to the nearest whole year.

61) _____

62) The revenue for a small company is given by the quadratic function $r(t) = 8t^2 + 4t + 950$ where t is the number of years since 1998 and $r(t)$ is in thousands of dollars. If this trend continues, find the year after 1998 in which the company's revenue will be \$1634 thousand. Round to the nearest whole year.

62) _____

63) The revenue for a small company is given by the quadratic function $r(t) = 11t^2 + 8t + 590$ where t is the number of years since 1998 and $r(t)$ is in thousands of dollars. If this trend continues, find the year after 1998 in which the company's revenue will be \$2009 thousand. Round to the nearest whole year.

63) _____

64) The revenue for a small company is given by the quadratic function $r(t) = 9t^2 + 17t + 760$ where t is the number of years since 1998 and $r(t)$ is in thousands of dollars. If this trend continues, find the year after 1998 in which the company's revenue will be \$1830 thousand. Round to the nearest whole year.

64) _____

- 65) The revenue for a small company is given by the quadratic function $r(t) = 8t^2 + 4t + 930$ where t is the number of years since 1998 and $r(t)$ is in thousands of dollars. If this trend continues, find the year after 1998 in which the company's revenue will be \$1074 thousand. Round to the nearest whole year. 65) _____

Solve.

66) $(3m - 7)^2 + 11(3m - 7) + 30 = 0$ 66) _____

67) $(2m - 7)^2 - 2(2m - 7) - 8 = 0$ 67) _____

68) $(2m - 6)^2 - 8(2m - 6) + 7 = 0$ 68) _____

69) $(3m - 6)^2 + 5(3m - 6) + 4 = 0$ 69) _____

70) $(4m - 2)^2 - 10(4m - 2) + 21 = 0$ 70) _____

71) $x - 27\sqrt{x} + 27 = 0$ 71) _____

72) $x - 24\sqrt{x} + 24 = 0$ 72) _____

73) $x - 40\sqrt{x} + 40 = 0$ 73) _____

Solve the problem.

74) If the cost, $C(x)$, for manufacturing x units of a certain product is given by 74) _____
 $C(x) = x^2 - 30x + 8800$, find the number of units manufactured at a cost of \$11,600.

75) If the cost, $C(x)$, for manufacturing x units of a certain product is given by 75) _____
 $C(x) = x^2 - 20x + 4800$, find the number of units manufactured at a cost of \$6300.

76) If the cost, $C(x)$, for manufacturing x units of a certain product is given by 76) _____
 $C(x) = x^2 - 20x + 800$, find the number of units manufactured at a cost of \$8800.

77) The side of a square equals the length of a rectangle. The width of the rectangle is 4 centimeters longer than its length. The sum of the areas of the square and the rectangle is 30 square centimeters. Find the side of the square. 77) _____

78) The side of a square equals the length of a rectangle. The width of the rectangle is 4 centimeters longer than its length. The sum of the areas of the square and the rectangle is 70 square centimeters. Find the side of the square. 78) _____

79) The side of a square equals the length of a rectangle. The width of the rectangle is 4 centimeters longer than its length. The sum of the areas of the square and the rectangle is 96 square centimeters. Find the side of the square. 79) _____

80) The side of a square equals the length of a rectangle. The width of the rectangle is 4 centimeters longer than its length. The sum of the areas of the square and the rectangle is 126 square centimeters. Find the side of the square. 80) _____

81) The side of a square equals the length of a rectangle. The width of the rectangle is 4 centimeters longer than its length. The sum of the areas of the square and the rectangle is 160 square centimeters. Find the side of the square.

81) _____

Graph the parabola whose equation is given.

82) $y = x^2 + 9$

82) _____

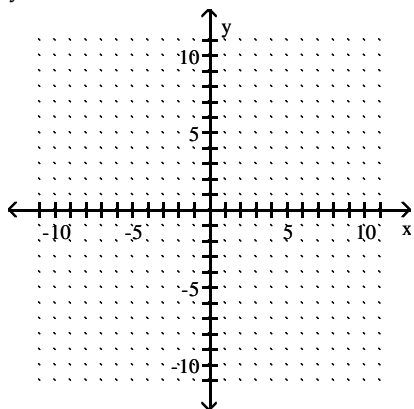

83) $y = x^2 + 1$

83) _____

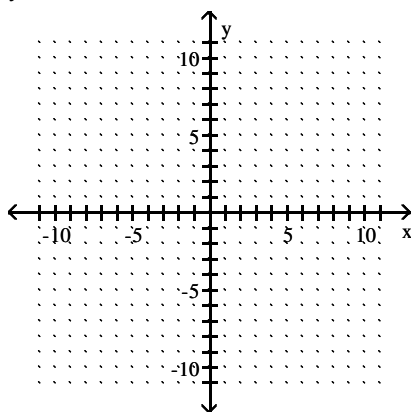

84) $y = x^2 - 6x$

84) _____

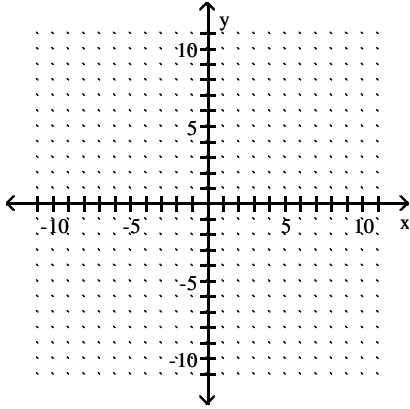

85) $y = x^2 - 4x$

85) _____

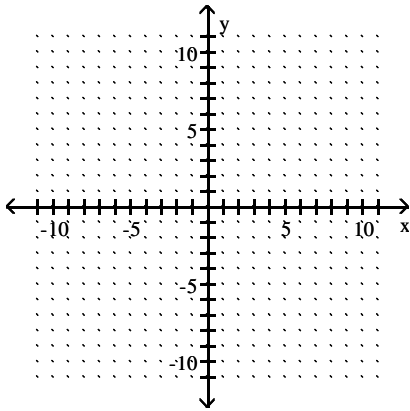

86) $y = x^2 + 2x - 8$

86) _____

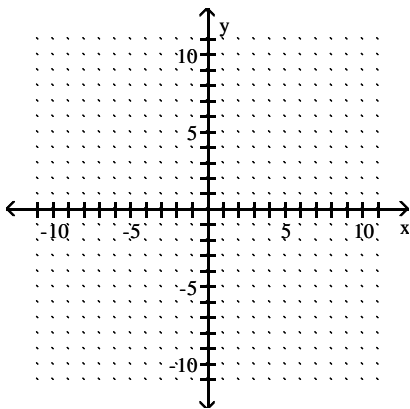

87) $y = x^2 - 2x - 8$

87) _____

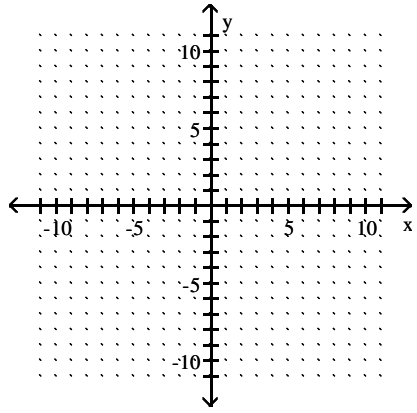

88) $y = -x^2 - 2x + 3$

88) _____

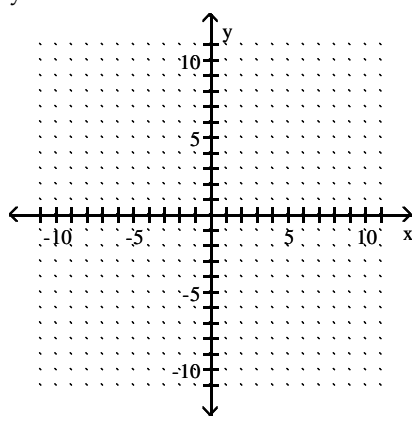

89) $y = -x^2 - 2x + 8$

89) _____

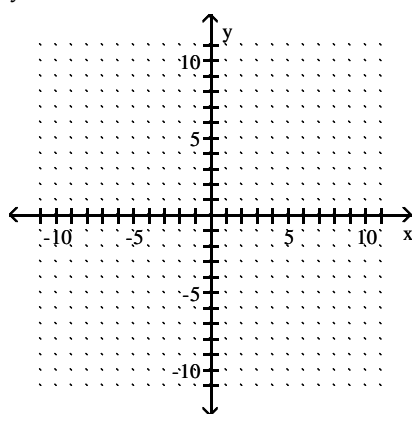

90) $y = 4x^2 + 24x + 35$

90) _____

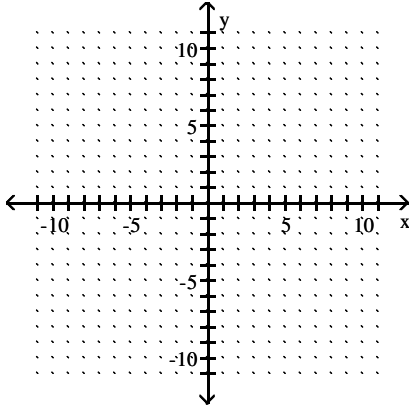

91) $y = -2x^2 + 20x - 49$

91) _____

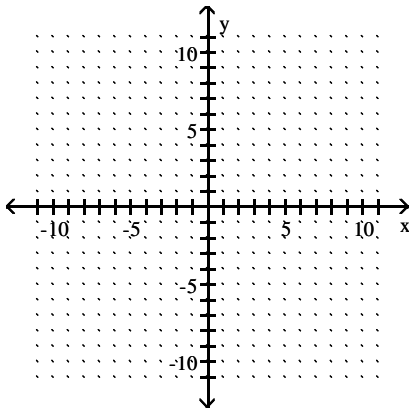

Sketch by hand the graph of the function. Give the coordinates for the vertex.

92) $y = x^2 - 4$

92) _____

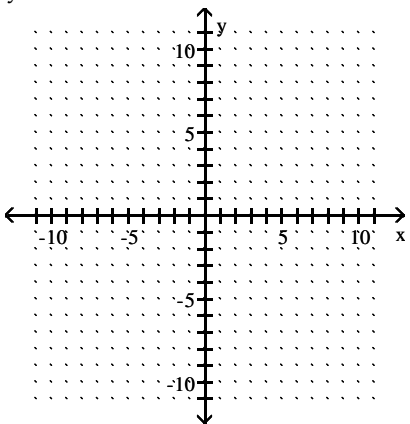

93) $y = x^2 + 5x + 4$

93) _____

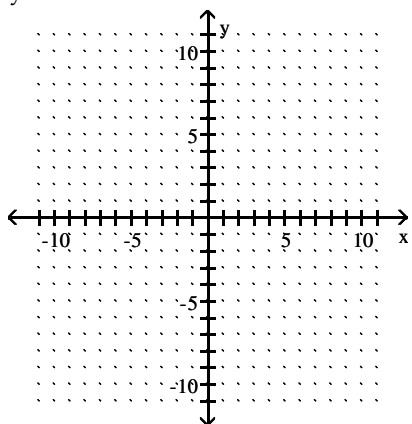

94) $y = x^2 + 4x + 8$

94) _____

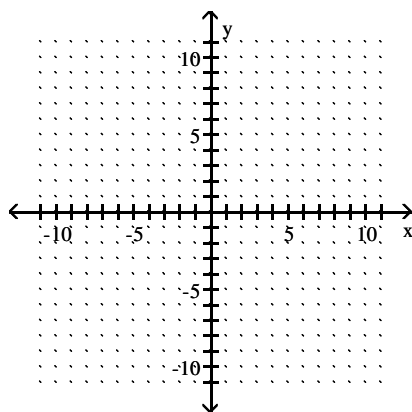

95) $y = -x^2 - 4x - 5$

95) _____

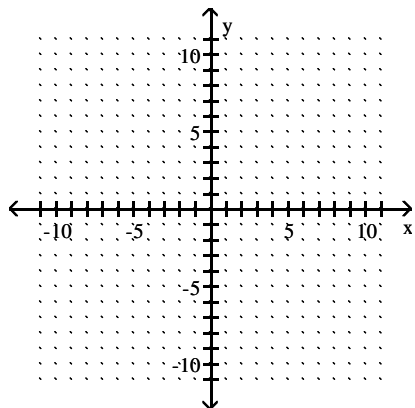

96) $y = 2x^2 - 12x + 20$

96) _____

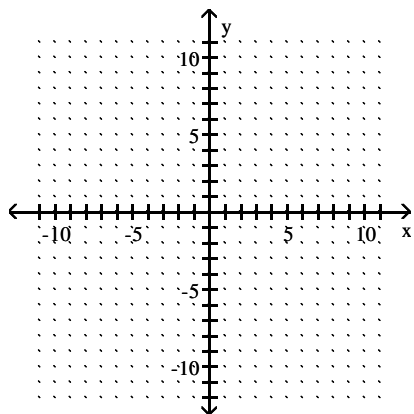

97) $y = -0.5x^2 + 0.6x + 1.1$

97) _____

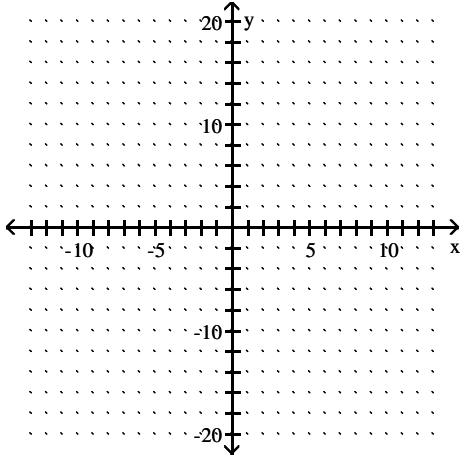

98) $y = 0.4x^2 + 2.7x - 6.3$

98) _____

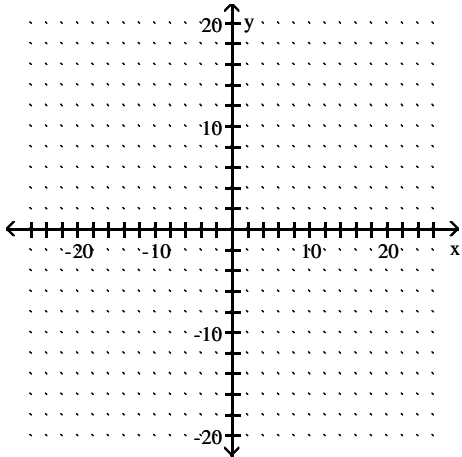

99) $3.3y - 6.2x = 7.1x^2 - 2.8$

99) _____

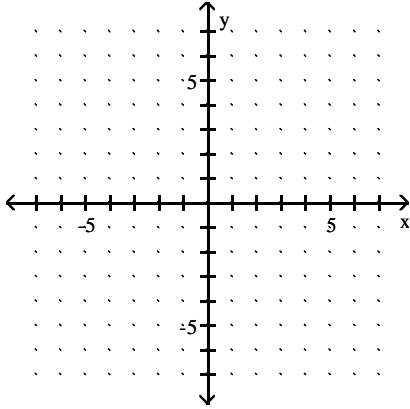

Find the vertex, the y-intercept, and the x-intercepts (if any exist), and graph the function.

100) $y = x^2 + 2x - 3$

100) _____

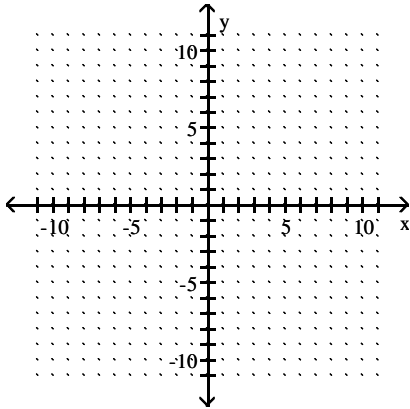

101) $y = 11x^2 - 22x$

101) _____

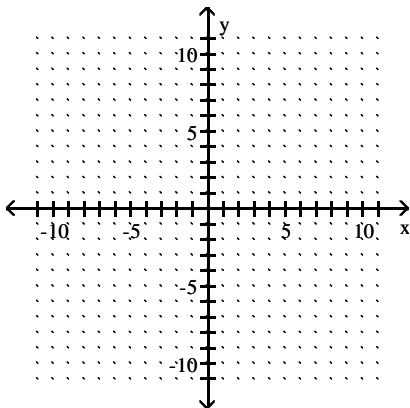

102) $y = -5x^2 - 10x$

102) _____

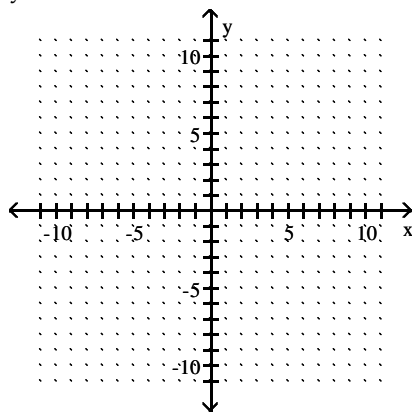

103) $y = -x^2 - 2x + 3$

103) _____

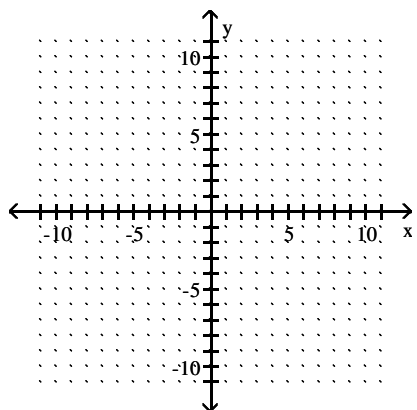

104) $y = x^2 - 4x + 4$

104) _____

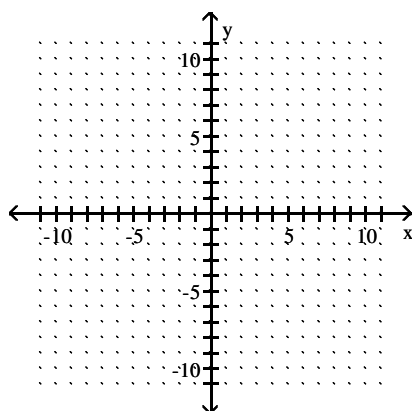

Solve.

105) John owns a hotdog stand. He has found that his profit is represented by the equation $P = -x^2 + 76x + 88$, with P being the profit in dollars, and x the number of hotdogs sold. How many hotdogs must he sell to earn the most profit? 105) _____

106) Bob owns a watch repair shop. He has found that the cost of operating his shop is given by $c = 3x^2 - 264x + 46$, where c is the cost in dollars, and x is the number of watches repaired. How many watches must he repair to have the lowest cost? 106) _____

107) Bob owns a watch repair shop. He has found that the cost of operating his shop is given by $c = 2x^2 - 116x + 68$, where c is the cost in dollars, and x is the number of watches repaired. How many watches must he repair to have the lowest cost? 107) _____

108) Which of the pairs of numbers whose sum is 74 has the largest product? 108) _____

109) Which of the pairs of numbers whose sum is 90 has the largest product? 109) _____

110) Which of the pairs of numbers whose sum is 74 has the largest product? 110) _____

111) The length and width of a rectangle have a sum of 74. What dimensions give the maximum area? 111) _____

112) The length and width of a rectangle have a sum of 70. What dimensions give the maximum area? 112) _____

113) The length and width of a rectangle have a sum of 80. What dimensions give the maximum area? 113) _____

114) The length and width of a rectangle have a sum of 84. What dimensions give the maximum area? 114) _____

115) Which of the pairs of numbers whose sum is 78 has the largest product? 115) _____

116) The length and width of a rectangle have a sum of 88. What dimensions give the maximum area? 116) _____

117) Which of the pairs of numbers whose sum is 76 has the largest product? 117) _____

118) Which of the pairs of numbers whose sum is 86 has the largest product? 118) _____

Solve the polynomial inequality, write solution using interval notation, and graph the solution set on a number line.

119) $x^2 + 10x + 24 > 0$ 119) _____

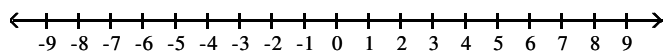

120) $x^2 + 13x + 42 > 0$ 120) _____

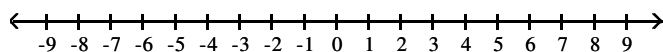

121) $x^2 - 5x + 4 > 0$

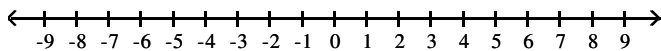

121) _____

122) $x^2 - 6x - 7 \leq 0$

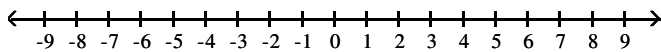

122) _____

123) $x^2 - 5x - 14 \leq 0$

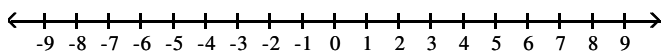

123) _____

124) $x^2 - 4x - 21 \leq 0$

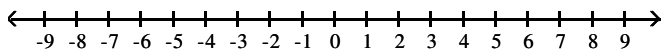

124) _____

125) $x^2 - 3x - 28 \leq 0$

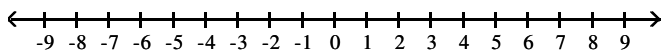

125) _____

126) $x^2 + 5x \geq -6$

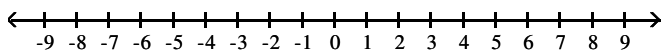

126) _____

127) $x^2 - 6x \geq -8$

127) _____

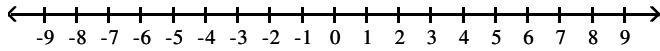

128) $3x^2 + 14x - 24 < 0$

128) _____

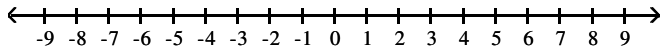

129) $4x^2 + 17x - 15 < 0$

129) _____

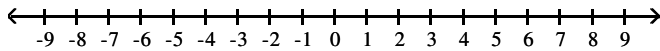

130) $x^2 - 3x \geq -2$

130) _____

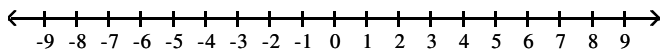

Use an inequality and the five-step process to solve the problem.

131) One side of a rectangle is 2 times the other, and the perimeter is not to exceed 84. Find the possible values for x , the length of the shorter side.

131) _____

132) One side of a rectangle is 4 inches and the other side is x inches. What values of x will make the perimeter at most 22?

132) _____

133) One side of a rectangle is 2 times the other, and the perimeter is not to exceed 60. Find the possible values for x , the length of the shorter side.

133) _____

- 134) One side of a triangle is 2 cm shorter than the base, x . The other side is 4 cm longer than the base. What lengths of the base will allow the perimeter of the triangle to be at least 32 cm? 134) _____
- 135) One side of a rectangle is 16 inches and the other side is x inches. Find the value of x if the area must be at least 208 square inches. 135) _____
- 136) One side of a rectangle is 10 inches and the other side is x inches. Find the value of x if the area must be at least 150 square inches. 136) _____
- 137) The area of a triangle must be at most 105 square inches, the base is 15 inches, and the height is x inches. Find the possible values for x . 137) _____
- 138) The area of a triangle must be at most 28 square inches, the base is 8 inches, and the height is x inches. Find the possible values for x . 138) _____

Answer Key

Testname: EXAM 3 PREP 6.1 TO 6.6 AND 7.1, 7.2 & 7.4 TO 7.6 V01

1) $\frac{2a^2}{b^4}$

2) $\frac{3a^2}{b^4}$

3) $\frac{4a^2}{b^4}$

4) $\frac{2a^2}{b^4}$

5) $\frac{3a^2}{b^4}$

6) $\frac{4a^2}{b^4}$

7) $2\sqrt{6} - 5$

8) $2\sqrt{42} - 13$

9) $\sqrt{x} - 10$

10) $\frac{x - 10\sqrt{x} + 25}{x - 25}$

11) $\frac{x + 22\sqrt{x} + 121}{x - 121}$

12) $\frac{x - 2\sqrt{x} + 1}{x - 1}$

13) $\left\{-\frac{10}{3}\right\}$

14) $\left\{-\frac{3}{2}\right\}$

15) $\left\{\frac{7}{6}\right\}$

16) $\left\{-\frac{5}{2}\right\}$

17) $\{2, 38\}$

18) $\{-3, 4\}$

19) $\{4, 12\}$

20) $\{8, 4\}$

21) $\{4, 8\}$

Answer Key

Testname: EXAM 3 PREP 6.1 TO 6.6 AND 7.1, 7.2 & 7.4 TO 7.6 V01

22) domain = $[-3, \infty)$, range = $[0, \infty)$

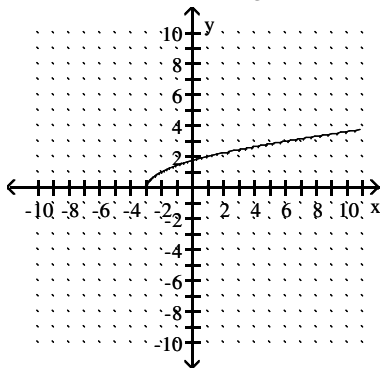

23) domain = $[-4, \infty)$, range = $[0, \infty)$

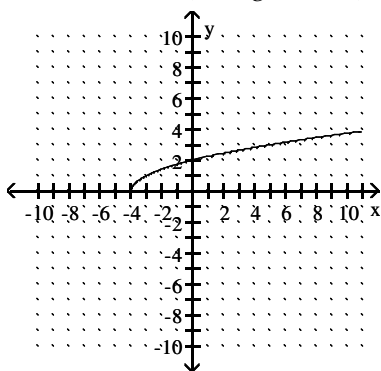

24) domain = $[3, \infty)$, range = $[0, \infty)$

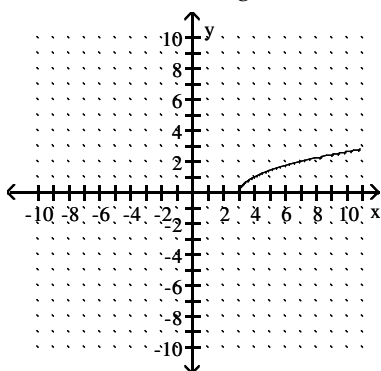

25) domain = $[2, \infty)$, range = $[0, \infty)$

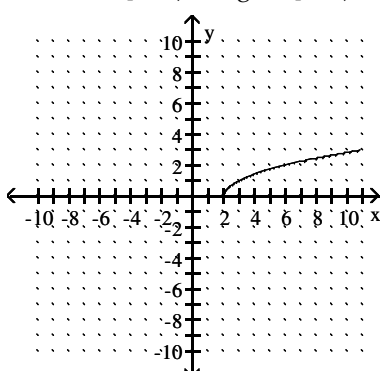

Answer Key

Testname: EXAM 3 PREP 6.1 TO 6.6 AND 7.1, 7.2 & 7.4 TO 7.6 V01

26) domain = $[0, \infty)$, range = $[-1, \infty)$

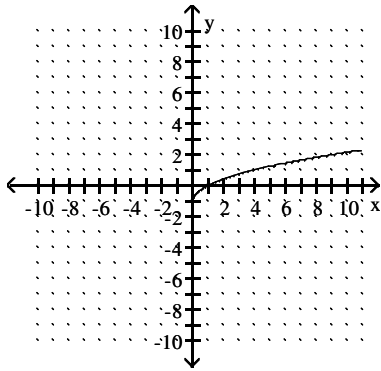

27) domain = $[0, \infty)$, range = $[3, \infty)$

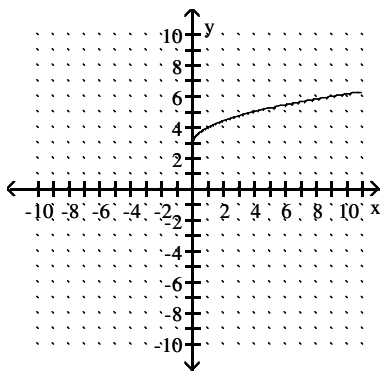

28) domain = $[0, \infty)$, range = $[-2, \infty)$

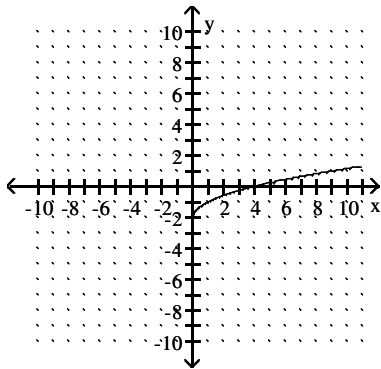

29) domain = $[0, \infty)$, range = $[2, \infty)$

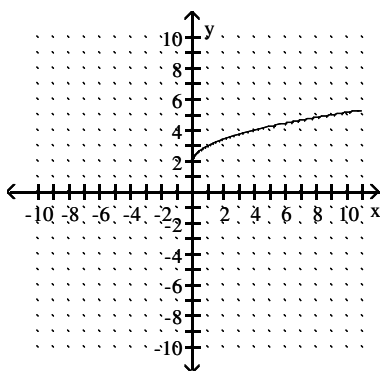

Answer Key

Testname: EXAM 3 PREP 6.1 TO 6.6 AND 7.1, 7.2 & 7.4 TO 7.6 V01

30) domain = $[0, \infty)$, range = $[4, \infty)$

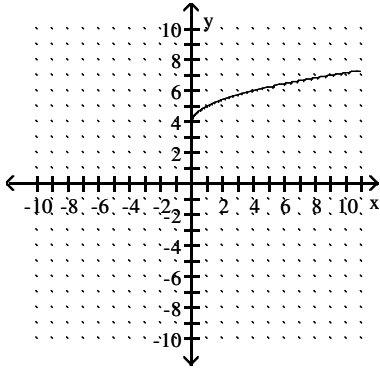

31) $5i$

32) $2i$

33) $18i$

34) $14i$

35) $13i$

36) $17i$

37) $8i$

38) $9i$

39) 1

40) 1

41) 1

42) 1

43) i

44) i

45) -1

46) $\{-4, 7\}$

47) $\{0, 3\}$

48) $\left\{ \frac{-3 \pm \sqrt{6}}{4} \right\}$

49) $\left\{ \frac{-5 \pm \sqrt{7}}{4} \right\}$

50) $\{-1, 6\}$

51) $\{-2, 3\}$

52) $\{-3, 6\}$

53) $\{2 \pm 11i\}$

54) $\{7 \pm 5i\}$

55) $\{7 \pm 3i\}$

56) $\{10 \pm 7i\}$

57) $\{11 \pm 12i\}$

58) $\{11 \pm 3i\}$

59) $\{2 \pm 9i\}$

60) $\{11 \pm 6i\}$

61) 2009

62) 2007

63) 2009

64) 2008

Answer Key

Testname: EXAM 3 PREP 6.1 TO 6.6 AND 7.1, 7.2 & 7.4 TO 7.6 V01

65) 2002

66) $\frac{1}{3}, \frac{2}{3}$

67) $\frac{5}{2}, \frac{11}{2}$

68) $\frac{7}{2}, \frac{13}{2}$

69) $\frac{2}{3}, \frac{5}{3}$

70) $\frac{5}{4}, \frac{9}{4}$

71) 9, 81

72) 16, 36

73) 25, 64

74) 70 units

75) 50 units

76) 100 units

77) 3 cm

78) 5 cm

79) 6 cm

80) 7 cm

81) 8 cm

82)

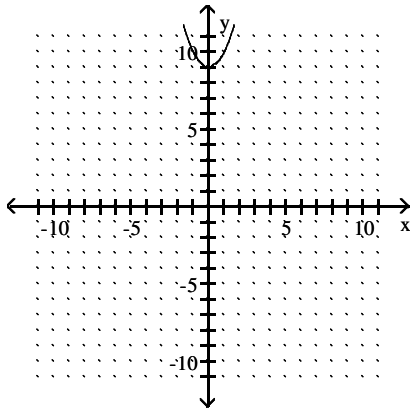

83)

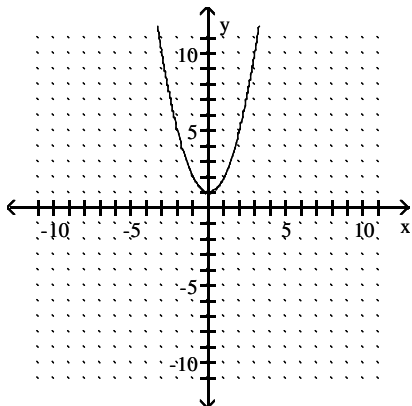

Answer Key

Testname: EXAM 3 PREP 6.1 TO 6.6 AND 7.1, 7.2 & 7.4 TO 7.6 V01

84)

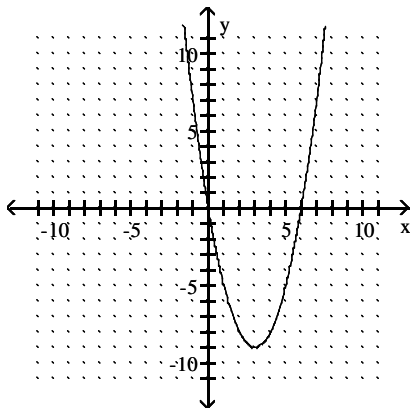

85)

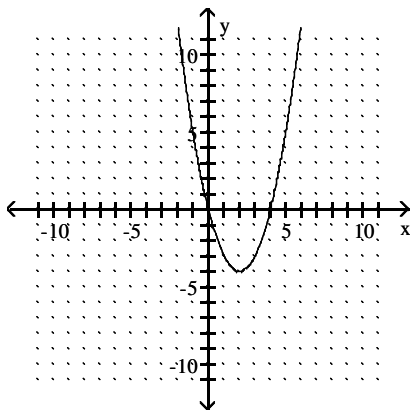

86)

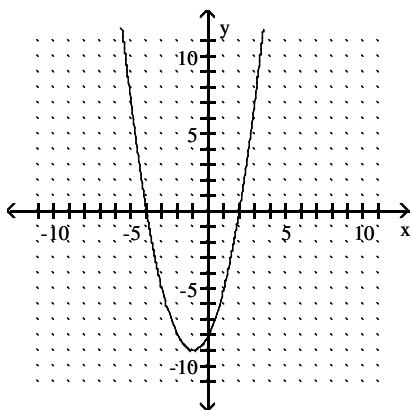

Answer Key

Testname: EXAM 3 PREP 6.1 TO 6.6 AND 7.1, 7.2 & 7.4 TO 7.6 V01

87)

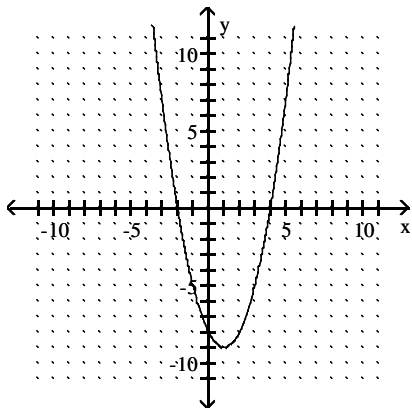

88)

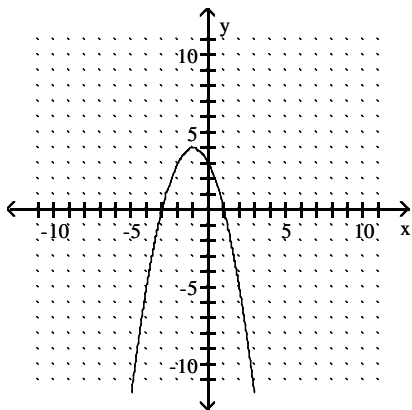

89)

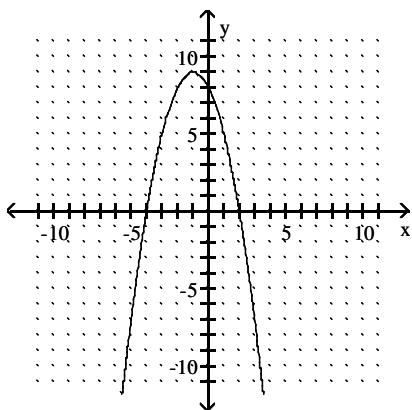

Answer Key

Testname: EXAM 3 PREP 6.1 TO 6.6 AND 7.1, 7.2 & 7.4 TO 7.6 V01

90)

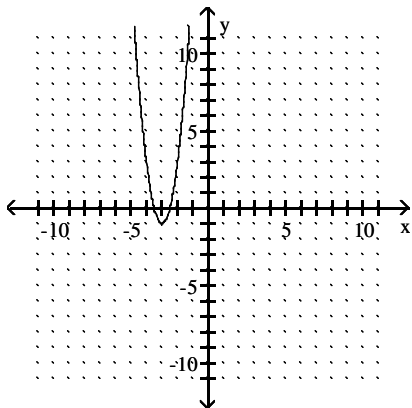

91)

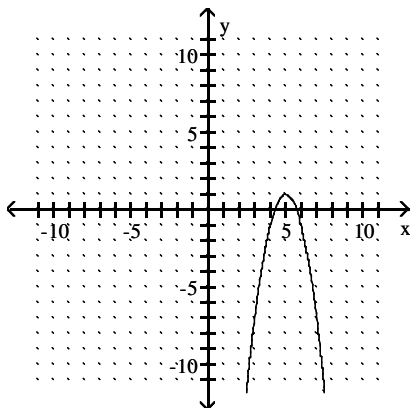

92) vertex: (0, -4)

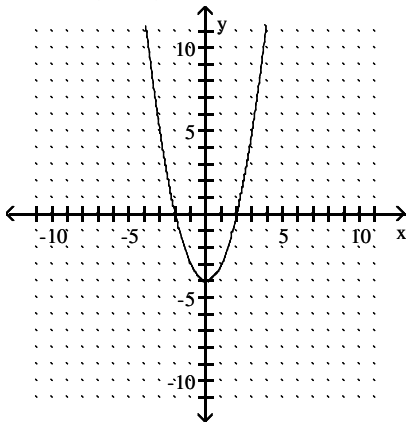

Answer Key

Testname: EXAM 3 PREP 6.1 TO 6.6 AND 7.1, 7.2 & 7.4 TO 7.6 V01

93) vertex: $\left(-\frac{5}{2}, -\frac{9}{4}\right)$

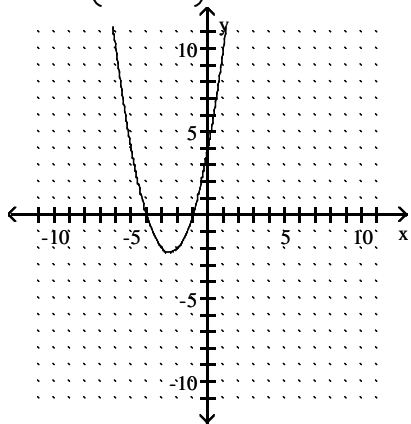

94) vertex: $(-2, 4)$

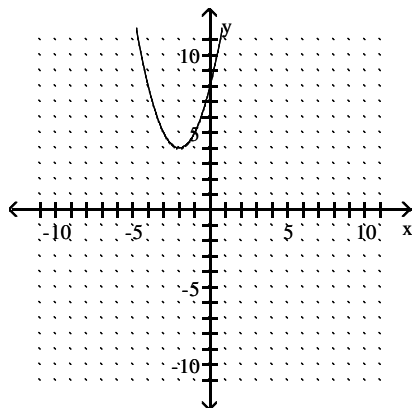

95) vertex: $(-2, -1)$

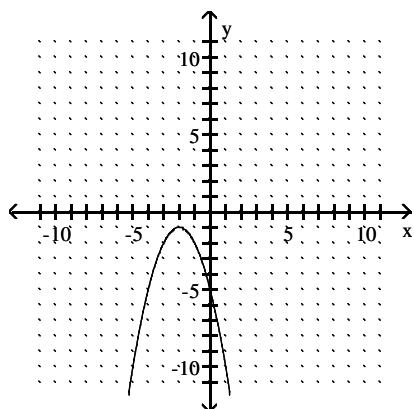

Answer Key

Testname: EXAM 3 PREP 6.1 TO 6.6 AND 7.1, 7.2 & 7.4 TO 7.6 V01

96) vertex: (3, 2)

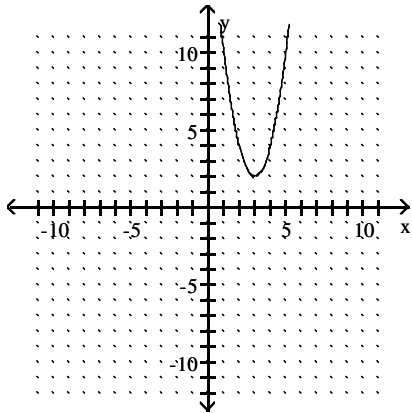

97) vertex: (0.6, 1.28)

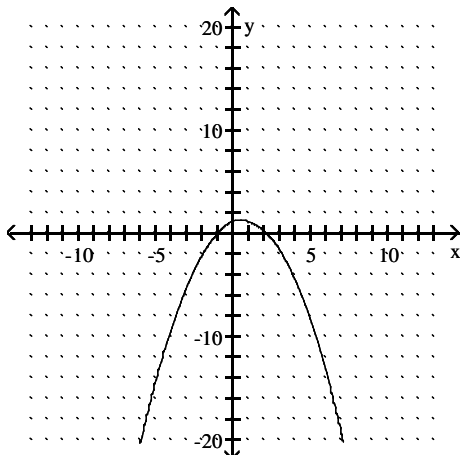

98) vertex: (-3.375, -10.85625)

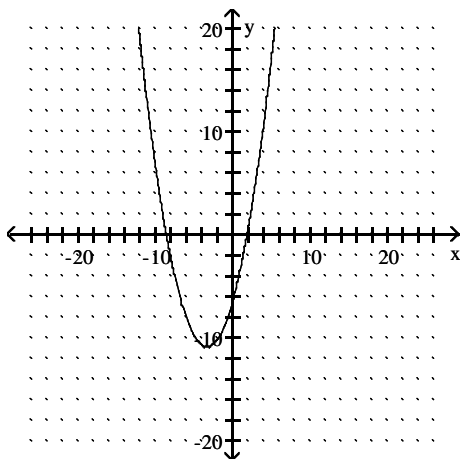

Answer Key

Testname: EXAM 3 PREP 6.1 TO 6.6 AND 7.1, 7.2 & 7.4 TO 7.6 V01

99) vertex: $(-0.44, -1.26)$

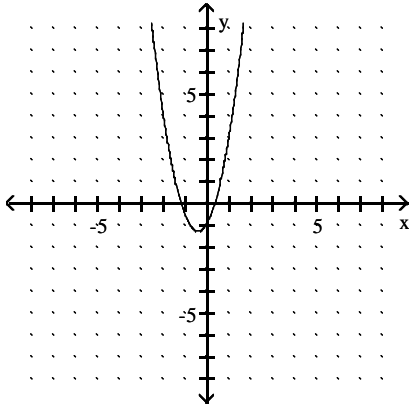

100) vertex $(-1, -4)$;
x-int: $(-3, 0)$ and $(1, 0)$;
y-int: $(0, -3)$

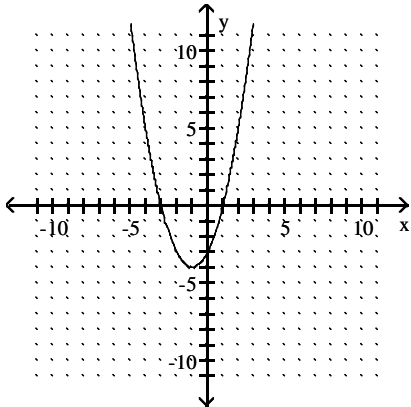

101) vertex $(1, -11)$;
x-int: $(0, 0)$ and $(2, 0)$;
y-int: $(0, 0)$

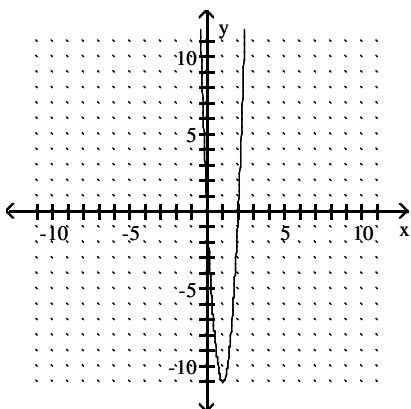

Answer Key

Testname: EXAM 3 PREP 6.1 TO 6.6 AND 7.1, 7.2 & 7.4 TO 7.6 V01

- 102) vertex $(-1, 5)$;
x-int: $(0, 0)$ and $(-2, 0)$;
y-int: $(0, 0)$

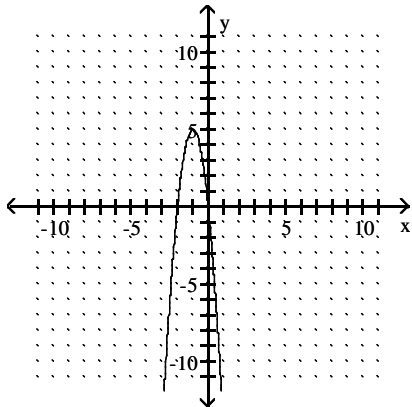

- 103) vertex $(-1, 4)$;
x-int: $(-3, 0)$ and $(1, 0)$;
y-int: $(0, 3)$

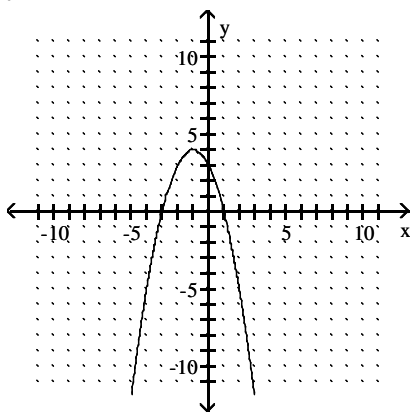

- 104) vertex $(2, 0)$;
x-int: $(2, 0)$;
y-int: $(0, 4)$

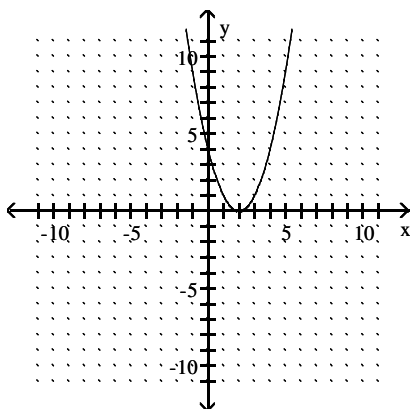

- 105) 38 hotdogs
106) 44 watches
107) 29 watches
108) 37 and 37
109) 45 and 45

Answer Key

Testname: EXAM 3 PREP 6.1 TO 6.6 AND 7.1, 7.2 & 7.4 TO 7.6 V01

110) 37 and 37

111) Length 37 and width 37

112) Length 35 and width 35

113) Length 40 and width 40

114) Length 42 and width 42

115) 39 and 39

116) Length 44 and width 44

117) 38 and 38

118) 43 and 43

119) $(-\infty, -6) \cup (-4, \infty)$

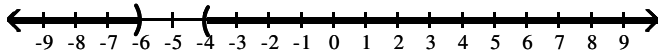

120) $(-\infty, -7) \cup (-6, \infty)$

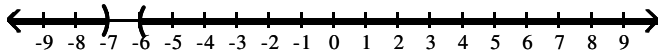

121) $(-\infty, 1) \cup (4, \infty)$

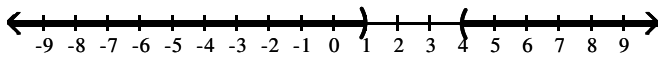

122) $[-1, 7]$

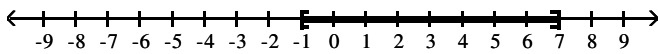

123) $[-2, 7]$

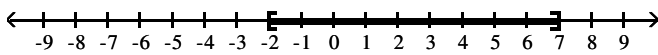

124) $[-3, 7]$

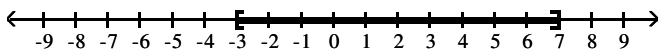

125) $[-4, 7]$

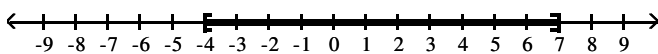

126) $(-\infty, -3] \cup [-2, \infty)$

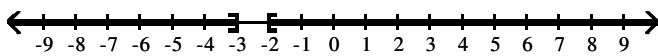

127) $(-\infty, 2] \cup [4, \infty)$

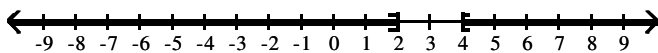

128) $\left[-6, \frac{4}{3}\right)$

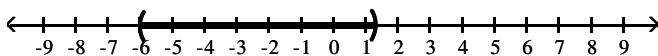

Answer Key

Testname: EXAM 3 PREP 6.1 TO 6.6 AND 7.1, 7.2 & 7.4 TO 7.6 V01

129) $\left(-5, \frac{3}{4}\right)$

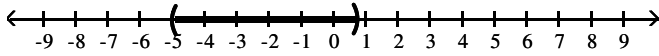

130) $(-\infty, 1] \cup [2, \infty)$

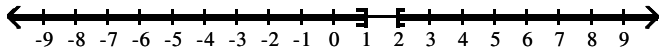

131) $0 < x \leq 14$

132) $0 < x \leq 7$

133) $0 < x \leq 10$

134) $x \geq 16$

135) $x \geq 13$

136) $x \geq 15$

137) $0 < x \leq 14$

138) $0 < x \leq 7$