

Name _____

Give the ordered pairs that correspond to the points labeled in the figure.

1)

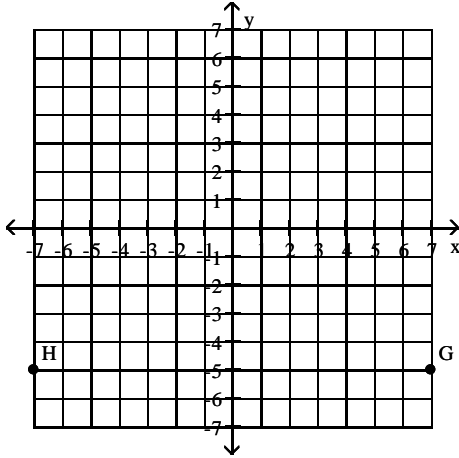

2)

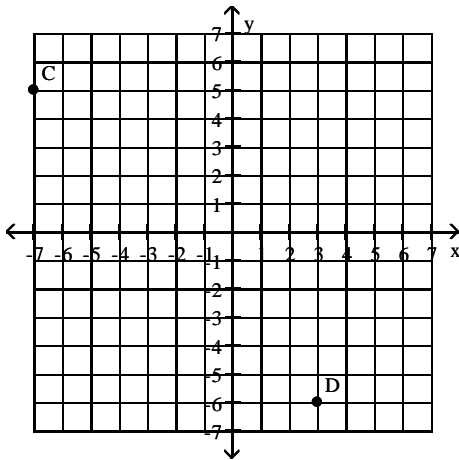

3)

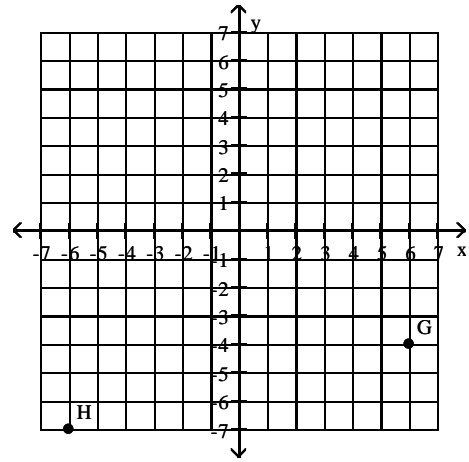

Determine whether the ordered pair is a solution of the given equation.

4) (4, 1)

$$y = x - 3$$

5) (-3, 4)

$$y = x - 1$$

6) (3, -6)

$$x - y = 9$$

7) (-6, -2)

$$x - y = 8$$

8) (1, 4)

$$3x + 4y = 19$$

9) (-4, -2)

$$2x + 4y = 0$$

Graph the linear equation in two variables.

10) $y = x + 3$

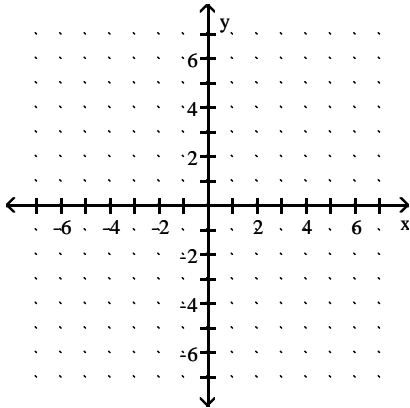

Find a solution to the equation using the value given for

x.

11) $y = -5x - 4$; $x = 2$

12) $y = -7x - 4$; $x = -4$

13) $y = 4x - 9$; $x = 4$

14) $y = 8x + 5$; $x = 0$

15) $y = 8x$; $x = 3$.

16) $y = 8x$; $x = 2$.

17) $y = 9x + 6$; $x = 2$

18) $y = -2x + 7$; $x = 2$

Solve the problem.

19) A customer at a store bought 3 bottles of juice and 5 fruit pies for a total cost of \$57.25. If x represents the cost of a bottle of juice and y represents the cost of one fruit pie, write an equation in two variables that reflects the given conditions.

20) A customer at a store bought 5 bottles of juice and 8 fruit pies for a total cost of \$105.25. If x represents the cost of a bottle of juice and y represents the cost of one fruit pie, write an equation in two variables that reflects the given conditions.

21) A customer at a store bought 4 bottles of juice and 3 fruit pies for a total cost of \$37.50. If a bottle of juice costs \$3.75, find the cost of a fruit pie.

22) A customer at a store bought 4 bottles of juice and 8 fruit pies for a total cost of \$83.00. If a bottle of juice costs \$3.75, find the cost of a fruit pie.

23) The linear equation in two variables $y = 0.20x + 225$ models the total weekly cost, y , in dollars, for renting a car and driving it x miles. The equation indicates that the rental company charges a fixed amount of \$225 for the week plus a cost of \$0.20 for each mile the car is driven. Find a solution of $y = 0.20x + 225$ using 265 for x .

24) The linear equation in two variables $y = 0.25x + 200$ models the total weekly cost, y , in dollars, for renting a car and driving it x miles. The equation indicates that the rental company charges a fixed amount of \$200 for the week plus a cost of \$0.25 for each mile the car is driven. Find a solution of $y = 0.25x + 200$ using 425 for x .

Graph the linear equation using the slope and y-intercept.

25) $y = 2x - 2$

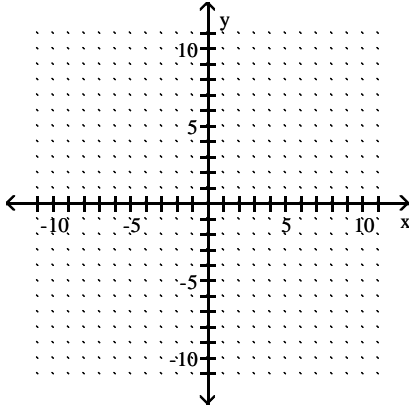

28) $y = \frac{5}{6}x - 2$

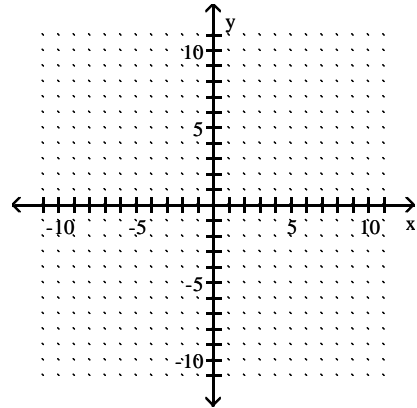

26) $y = 2x + 5$

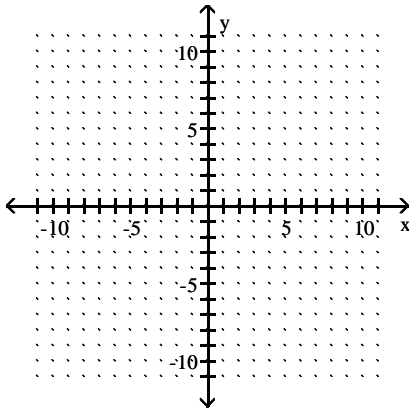

29) $y = -\frac{1}{2}x$

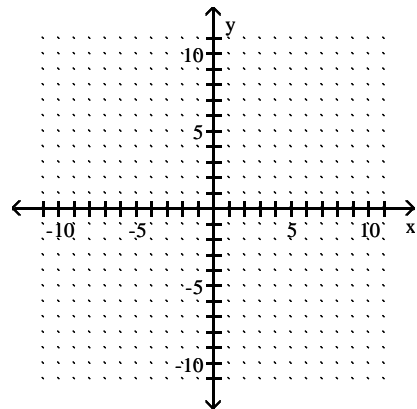

27) $y = \frac{3}{4}x - 4$

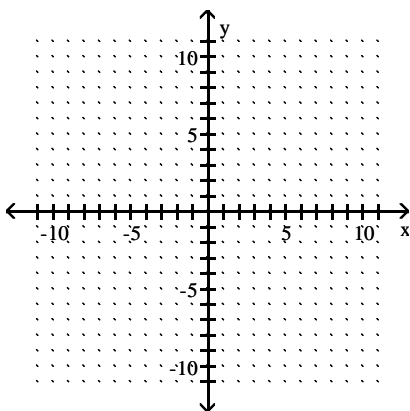

30) $y = \frac{1}{2}x$

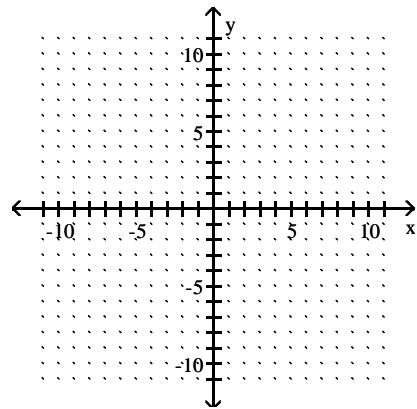

Graph the equation.

31) $y = 5$

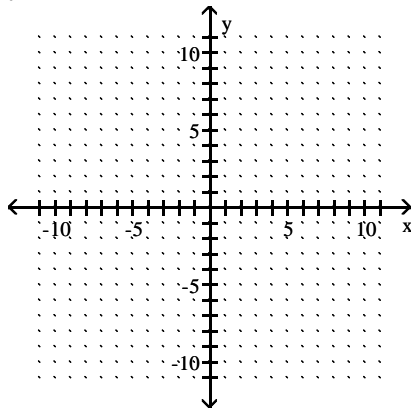

34) $y + 5 = 0$

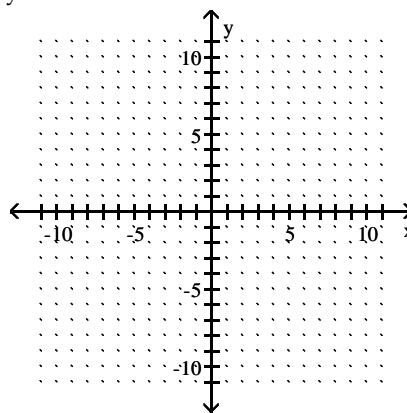

32) $x = 9$

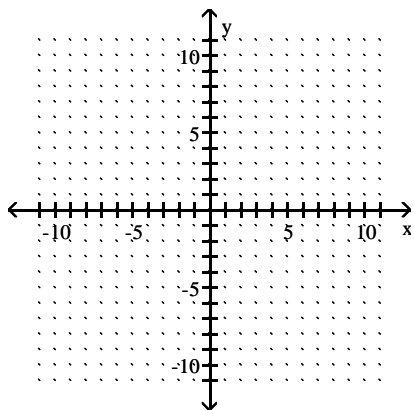

35) $x + 2 = 0$

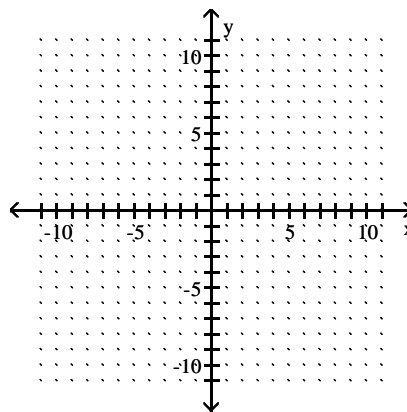

33) $y + 4 = 0$

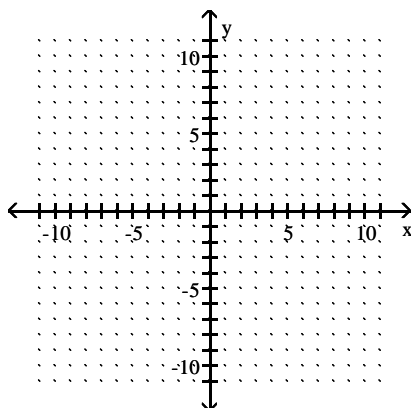

36) $x + 5 = 0$

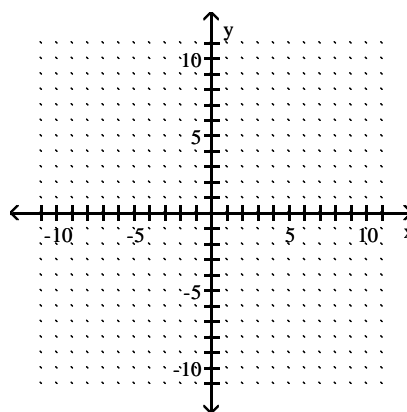

37) $x = 6$

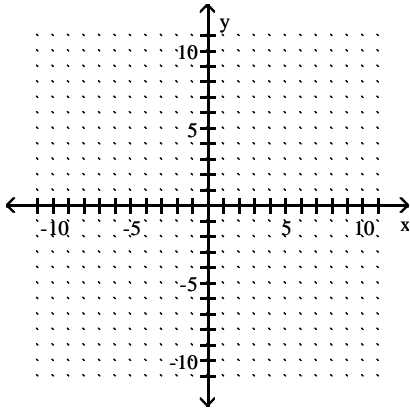

Write an equation for the graph.

40)

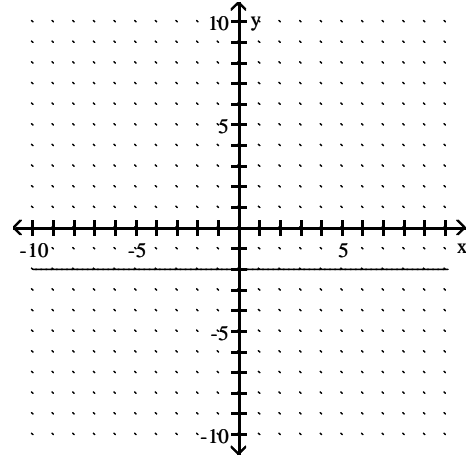

38) $y = 1$

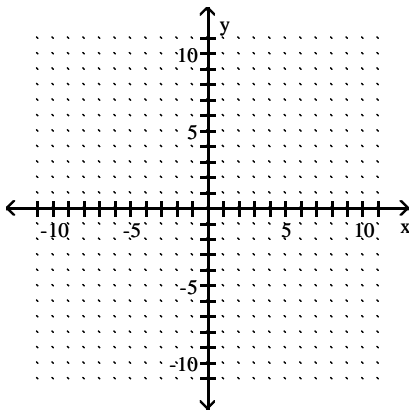

41)

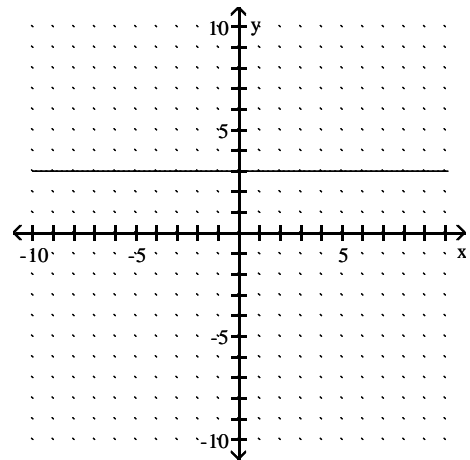

39) $y = -8$

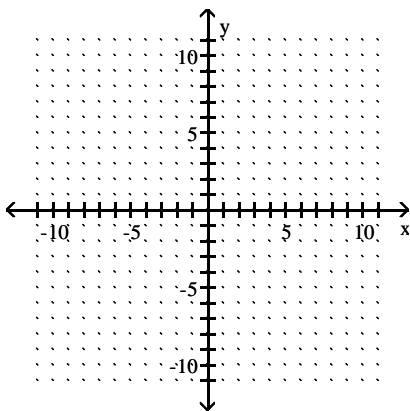

42)

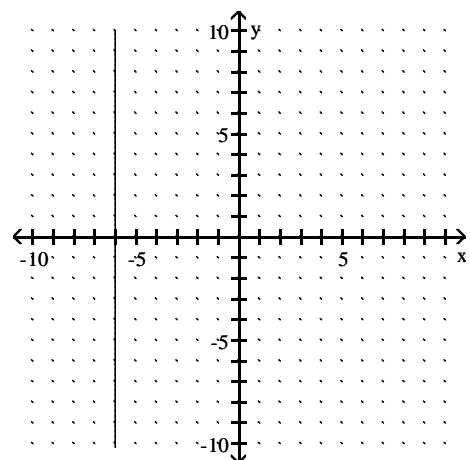

Find the slope of the line passing through the pair of points or state that the slope is undefined.

43) $(-3, 7)$ and $(-3, 9)$

44) $(9, -3)$ and $(9, 6)$

45) $(-5, -6)$ and $(-5, -9)$

46) $(-9, -8)$ and $(7, -8)$

47) $(3, 2)$ and $(-5, 2)$

48) $(8, 6)$ and $(-3, 6)$

Find the slope of the line.

49) $y = 8 - x$

50) $y = 2 - x$

51) $-4x + y = -8$

52) $-5x + y = 12$

53) $2x + 4y = 4$

54) $5x + 7y = -2$

55) $3x + 2y = -8$

Find the y-intercept.

56) $y = 4x$

57) $y = -3x$

58) $y = -2x$

59) $y = 4$

60) $y = 8$

61) $5x + y = -2$

62) $-3x + y = 8$

63) $3x + y = 0$

64) $5x + y = 0$

Find the slope of the line.

65) $y = -5x - 8$

66) $y = \frac{6}{7}x + 5$

67) $-5x + y = 6$

68) $2x - 3y = 8$

Find the point-slope form of the equation of the line satisfying the given conditions and use this to write the slope-intercept form of the equation.

69) Slope = 3, passing through (5, 2)

70) Slope = 4, passing through (3, 2)

71) Passing through (-5, 7), (7, -5)

72) Passing through (1, 5), (5, 1)

73) Passing through (0, 7) and (8, 9)

74) Passing through (9, -6) and (3, -4)

75) x-intercept = $\frac{3}{2}$ and y-intercept = 2

76) x-intercept = $\frac{3}{2}$ and y-intercept = 4

77) x-intercept = $-\frac{5}{2}$ and y-intercept = 4

78) x-intercept = 7 and y-intercept = 3

79) x-intercept = -7 and y-intercept = 1

Write an equation in slope-intercept form of the line satisfying the given conditions.

80) Parallel to the line $y = -4x - 1$; containing the point (2, 6)

81) Parallel to the line $y = 5x - 8$; containing the point (7, 2).

82) Parallel to the line $4x + 5y = 77$; containing the point (8, 5).

83) Perpendicular to the line $x + 3y = -3$; containing the point (1, 4).

Determine if the ordered pair satisfies the inequality.

84) $x + y > -4$: (-1, 0)

85) $y > -x + 5$: (5, 1)

86) $y > -x + 3$: (-3, 9)

87) $x \leq y - 7$: (-2, 4)

88) $x \leq y + 4$: (5, -1)

89) $x + y > -3$: (-4, 4)

90) $x - y \leq 1$: (-1, 2)

91) $x - y \leq 4$: (-5, 1)

92) $x - y \leq -4$: (2, 3)

93) $x - y \leq -3$: (1, 2)

94) $2x + 3y \leq -6$: (-3, 1)

95) $2x + 3y \leq -3$: (3, 6)

98) $x + y < -3$

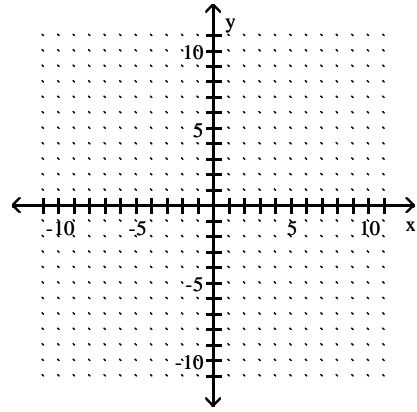

Graph the inequality.

96) $x - y > -6$

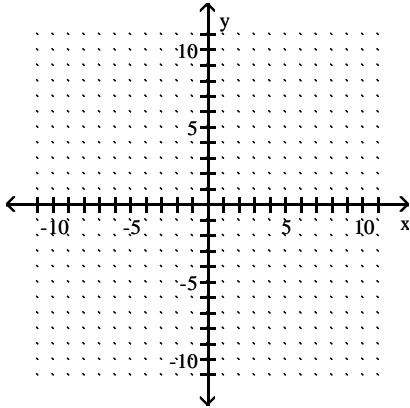

99) $x + y \leq 3$

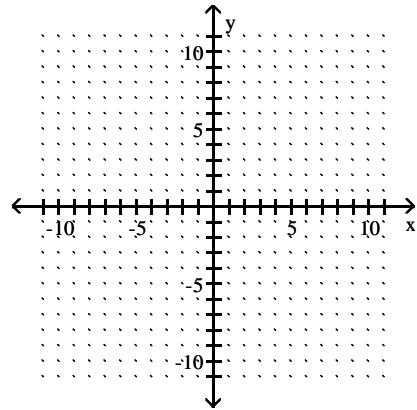

97) $x + y < -6$

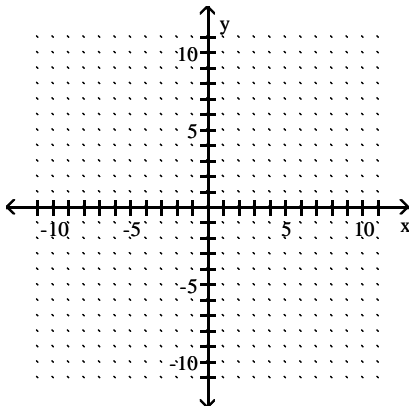

100) $5x + y \leq 5$

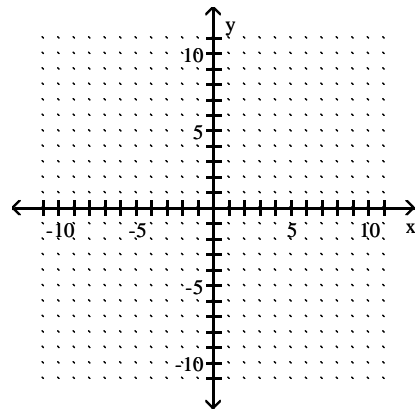

101) $x + 3y \geq 3$

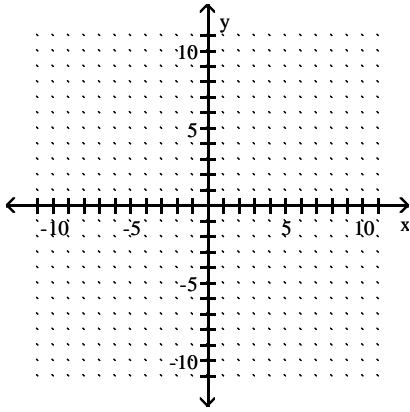

104) $-3x - 5y \leq 15$

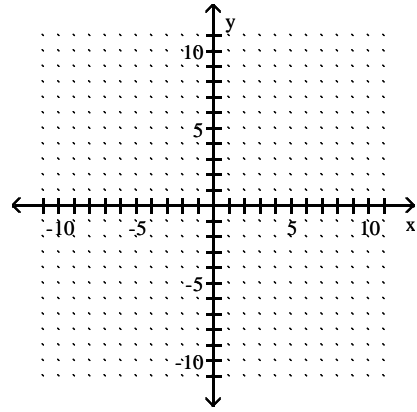

102) $-3x + y \leq 9$

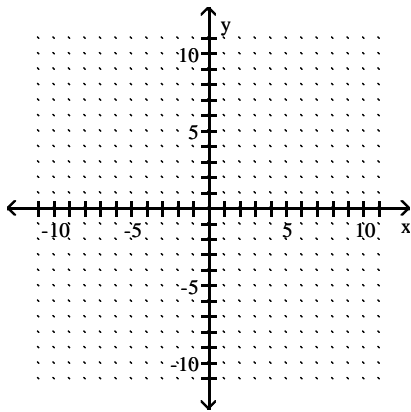

105) $3x + 4y \geq -12$

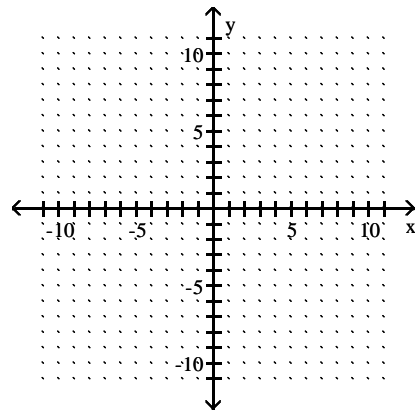

103) $2x + 4y \leq 8$

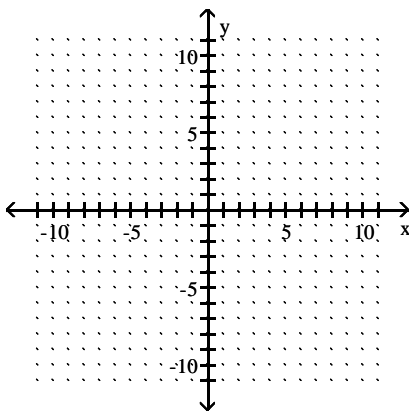

106) $y \geq -2x$

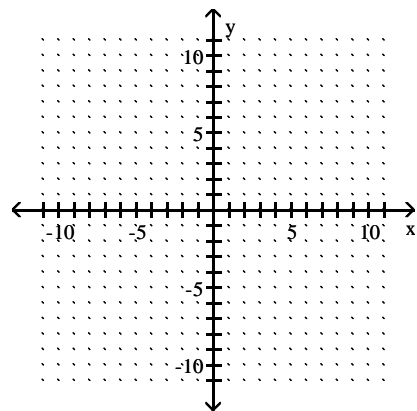

107) $y < \frac{1}{5}x$

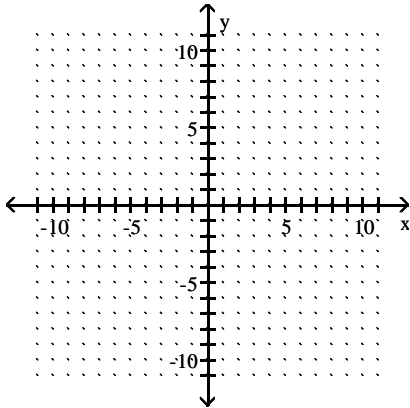

110) $y \leq -6$

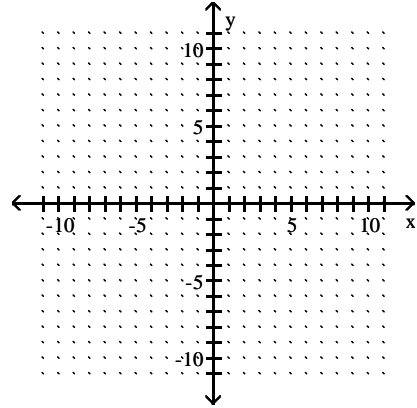

108) $y \leq -4x + 2$

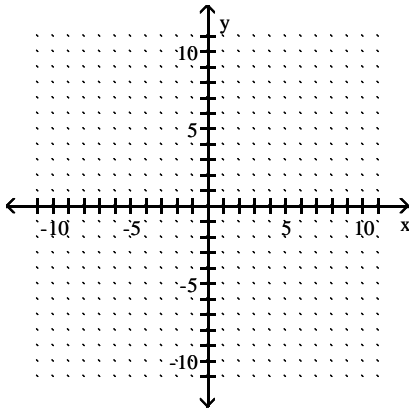

109) $x > 3$

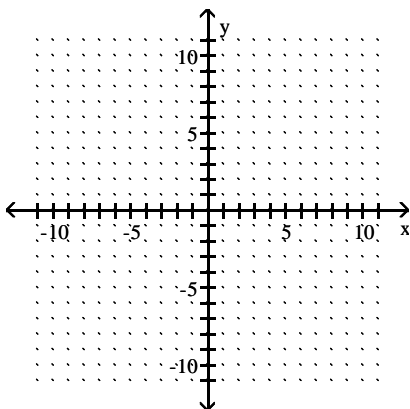

Solve.

111) A woman works out by running and swimming. When she runs, she burns 7 calories per minute. When she swims, she burns 10 calories per minute. She wants to burn at least 350 calories in her workout. These data are summarized by the linear inequality $7x + 10y \geq 350$. Graph an inequality that describes when x minutes running and y minutes swimming will burn at least as many calories as the woman wants to burn.

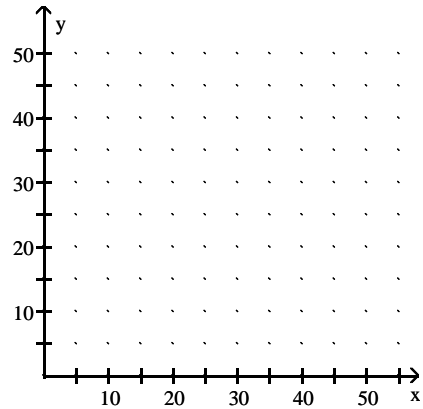

Answer Key

Testname: E02PREP_3.3TO3.6V01

1) $G = (7, -5), H = (-7, -5)$

2) $C = (-7, 5), D = (3, -6)$

3) $G = (6, -4), H = (-6, -7)$

4) Yes

5) No

6) Yes

7) No

8) Yes

9) No

10)

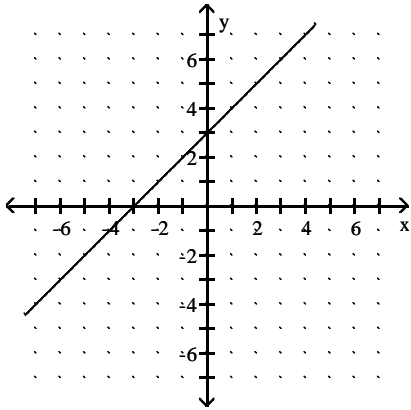

11) $(2, -14)$

12) $(-4, 24)$

13) $(4, 7)$

14) $(0, 5)$

15) $(3, 24)$

16) $(2, 16)$

17) $(2, 24)$

18) $(2, 3)$

19) $3x + 5y = 57.25$

20) $5x + 8y = 105.25$

21) \$7.50

22) \$8.50

23) $(265, 278)$

24) $(425, 306.25)$

25)

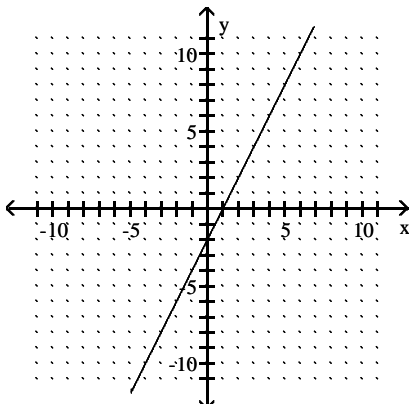

Answer Key

Testname: E02PREP_3.3TO3.6V01

26)

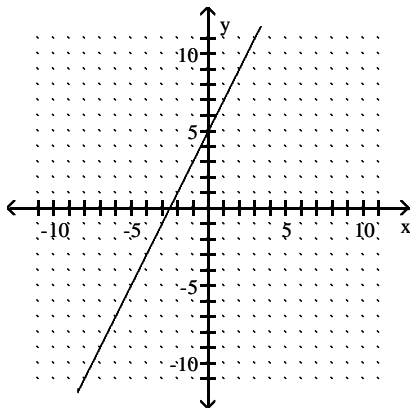

27)

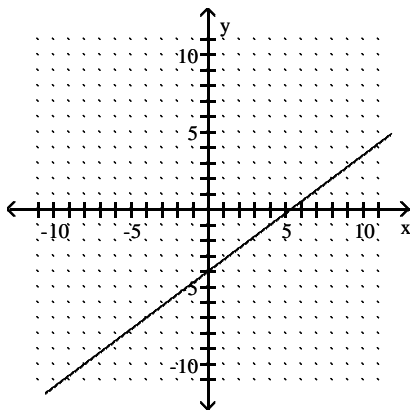

28)

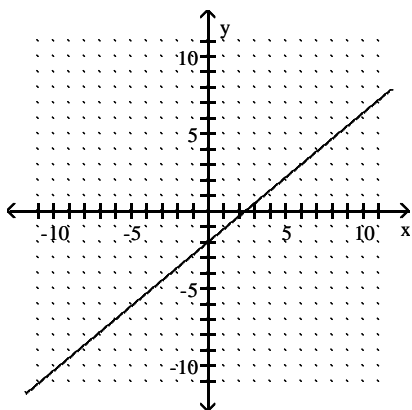

Answer Key

Testname: E02PREP_3.3TO3.6V01

29)

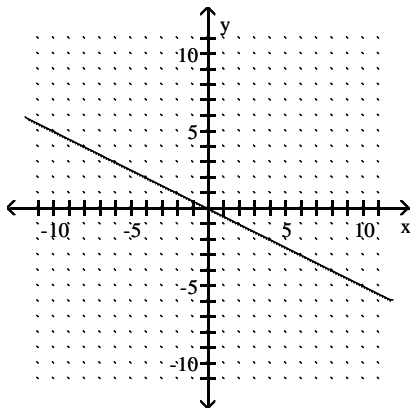

30)

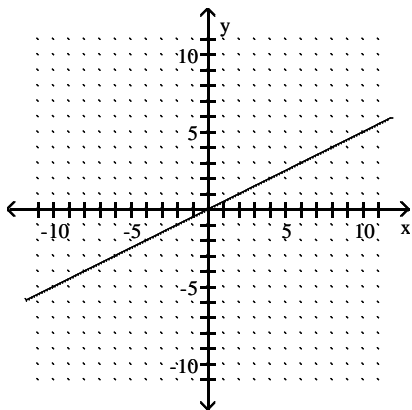

31)

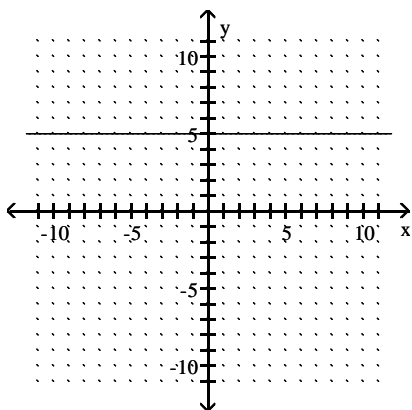

Answer Key

Testname: E02PREP_3.3TO3.6V01

32)

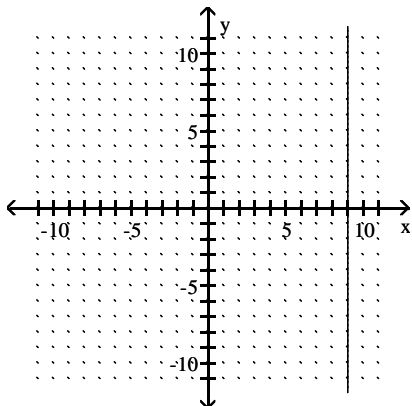

33)

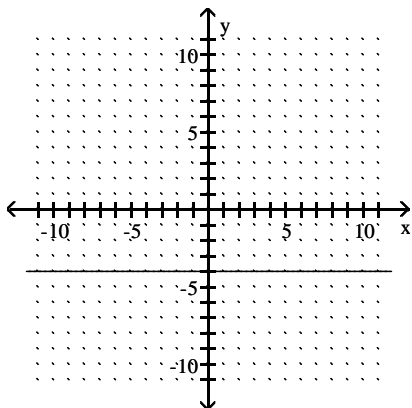

34)

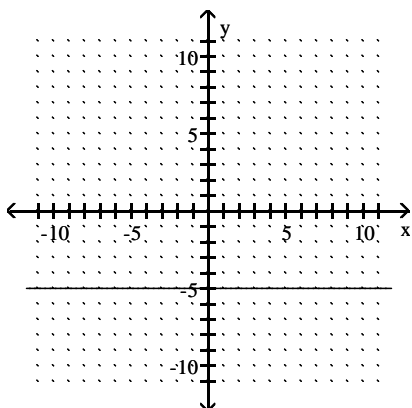

Answer Key

Testname: E02PREP_3.3TO3.6V01

35)

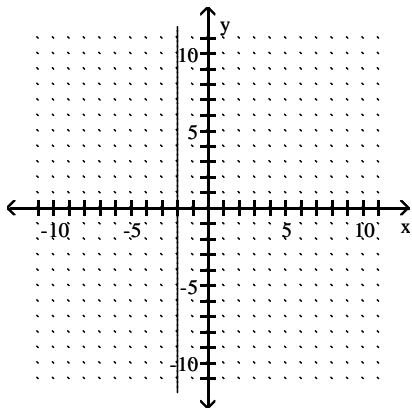

36)

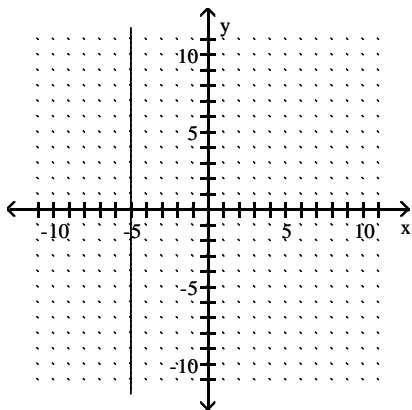

37)

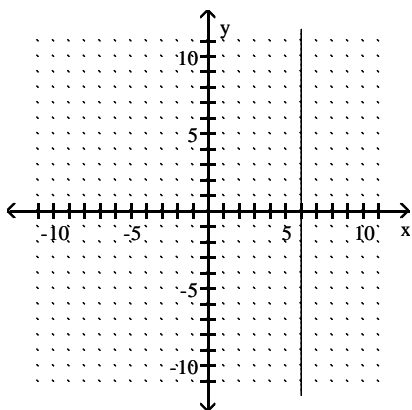

Answer Key

Testname: E02PREP_3.3TO3.6V01

38)

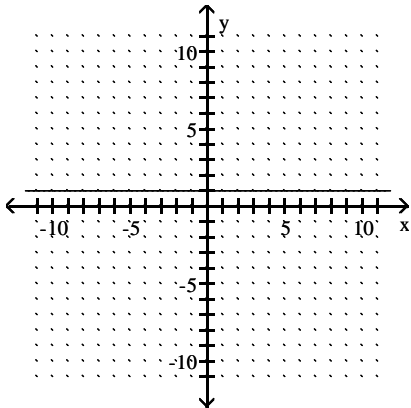

39)

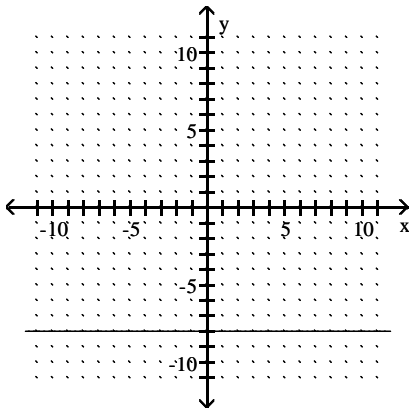

40) $y = -2$

41) $y = 3$

42) $x = -6$

43) undefined

44) undefined

45) undefined

46) 0

47) 0

48) 0

49) -1

50) -1

51) 4

52) 5

53) $-\frac{1}{2}$

54) $-\frac{5}{7}$

55) $-\frac{3}{2}$

56) 0

57) 0

58) 0

59) 4

Answer Key

Testname: E02PREP_3.3TO3.6V01

60) 8

61) - 2

62) 8

63) 0

64) 0

65) - 5

66) $\frac{6}{7}$

67) 5

68) $\frac{2}{3}$

69) $y = 3x - 13$

70) $y = 4x - 10$

71) $y = -x + 2$

72) $y = -x + 6$

73) $y = \frac{1}{4}x + 7$

74) $y = -\frac{1}{3}x - 3$

75) $y = -\frac{4}{3}x + 2$

76) $y = -\frac{8}{3}x + 4$

77) $y = \frac{8}{5}x + 4$

78) $y = -\frac{3}{7}x + 3$

79) $y = \frac{1}{7}x + 1$

80) $y = -4x + 14$

81) $y = 5x - 33$

82) $y = -\frac{4}{5}x + \frac{57}{5}$

83) $y = 3x + 1$

84) Yes

85) Yes

86) Yes

87) No

88) No

89) Yes

90) Yes

91) Yes

92) No

93) No

94) No

95) No

Answer Key

Testname: E02PREP_3.3TO3.6V01

96)

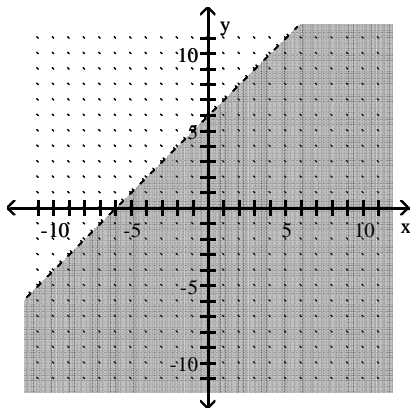

97)

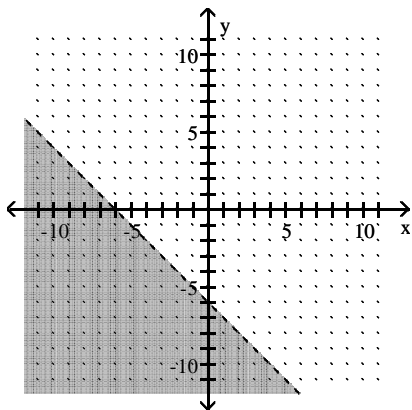

98)

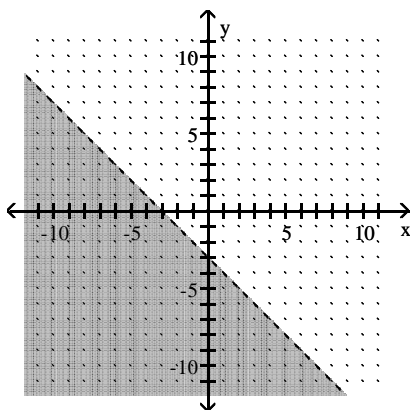

Answer Key

Testname: E02PREP_3.3TO3.6V01

99)

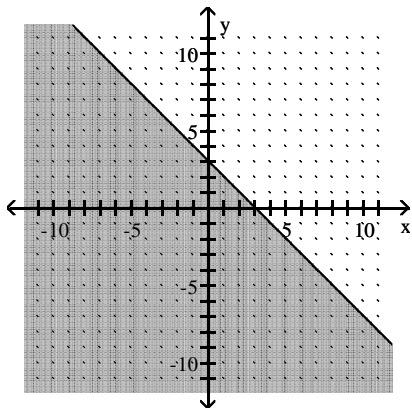

100)

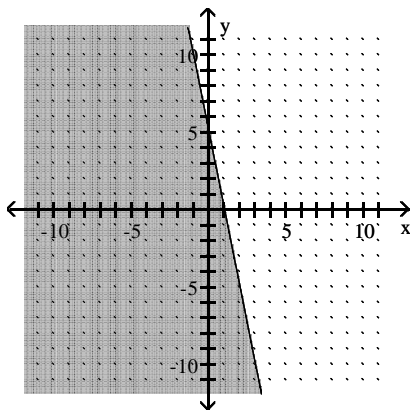

101)

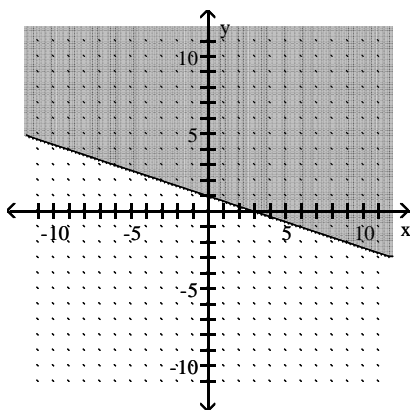

Answer Key

Testname: E02PREP_3.3TO3.6V01

102)

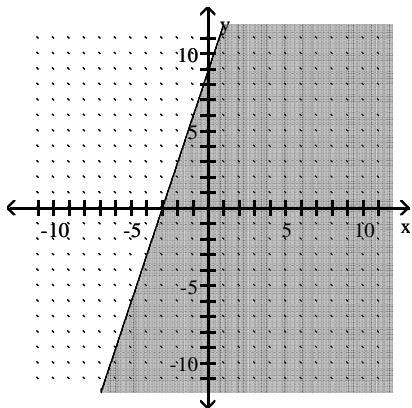

103)

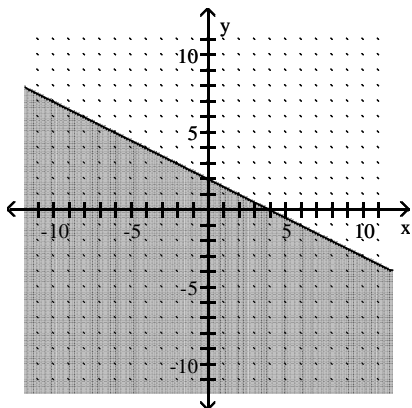

104)

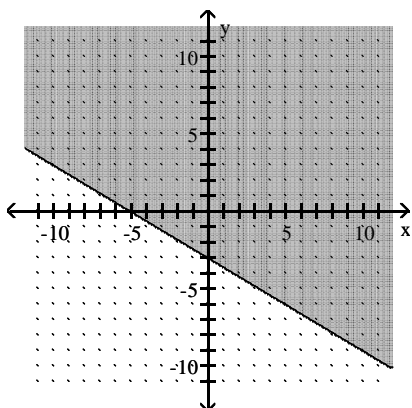

Answer Key

Testname: E02PREP_3.3TO3.6V01

105)

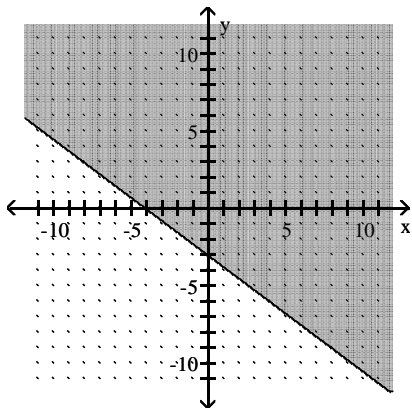

106)

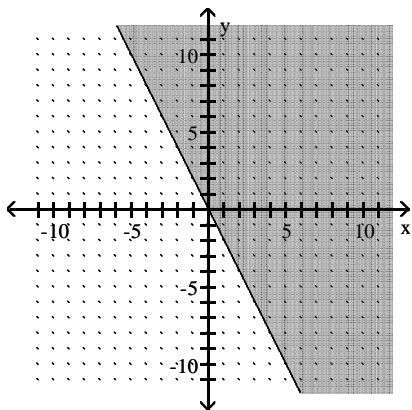

107)

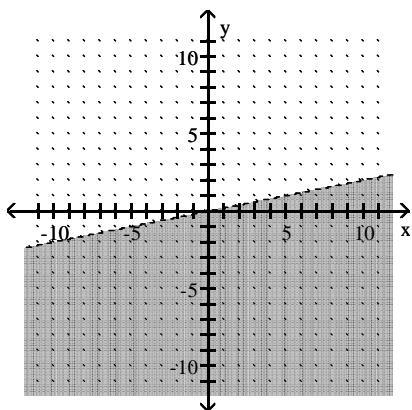

Answer Key

Testname: E02PREP_3.3TO3.6V01

108)

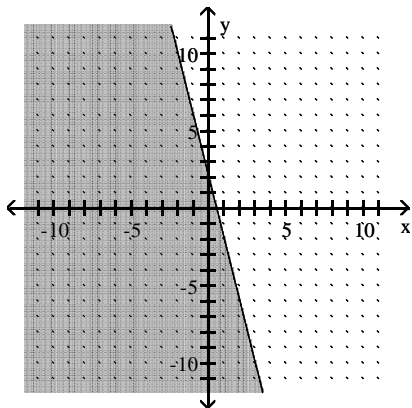

109)

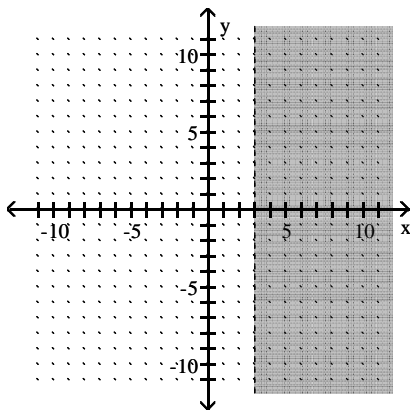

110)

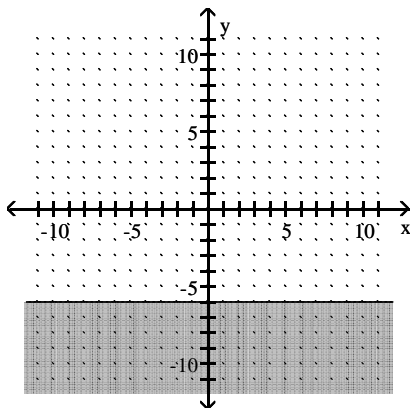

Answer Key

Testname: E02PREP_3.3TO3.6V01

111)

