

Name \_\_\_\_\_

Give the ordered pairs that correspond to the points labeled in the figure.

1)

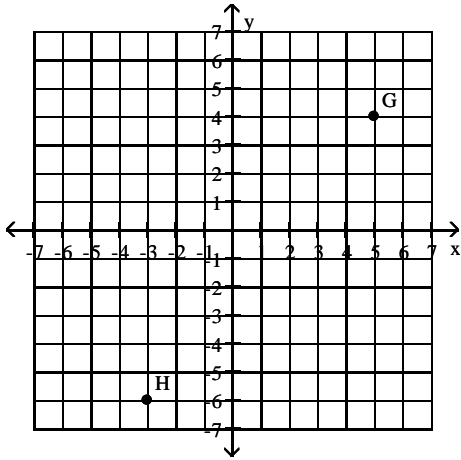

2)

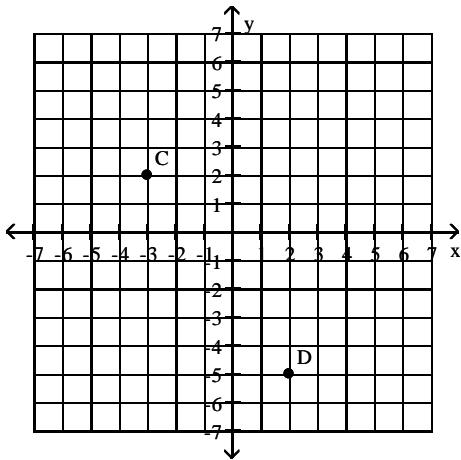

3)

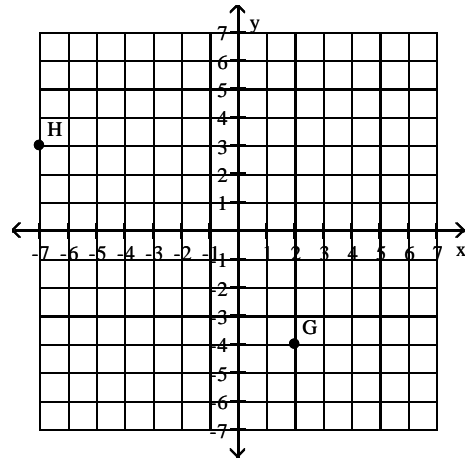

Determine whether the ordered pair is a solution of the given equation.

4)  $(-3, -2)$

$y = x + 1$

5)  $(-6, -5)$

$y = x + 11$

6)  $(3, 1)$

$x - y = 2$

7)  $(3, 2)$

$x - y = -5$

8)  $(1, 3)$

$2x + 3y = 11$

9)  $(1, -4)$

$2x + 3y = 14$

**Graph the linear equation in two variables.**

10)  $y = x - 2$

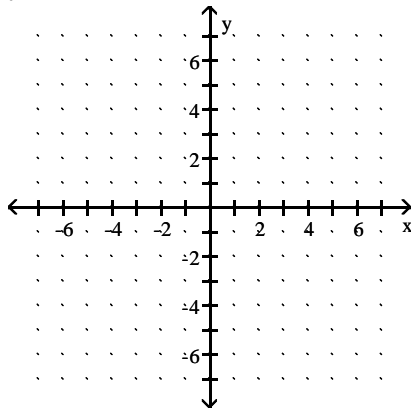

**Find a solution to the equation using the value given for**

**x.**

11)  $y = -2x - 7$ ;  $x = -3$

12)  $y = -6x - 7$ ;  $x = 4$

13)  $y = 6x - 4$ ;  $x = 2$

14)  $y = 4x + 5$ ;  $x = 4$

15)  $y = 8x$ ;  $x = -3$ .

16)  $y = 3x$ ;  $x = -4$ .

17)  $y = 3x + 8$ ;  $x = 6$

18)  $y = 7x + 3$ ;  $x = 0$

**Solve the problem.**

19) A customer at a store bought 8 bottles of juice and 6 fruit pies for a total cost of \$73.00. If  $x$  represents the cost of a bottle of juice and  $y$  represents the cost of one fruit pie, write an equation in two variables that reflects the given conditions.

20) A customer at a store bought 4 bottles of juice and 8 fruit pies for a total cost of \$79.00. If  $x$  represents the cost of a bottle of juice and  $y$  represents the cost of one fruit pie, write an equation in two variables that reflects the given conditions.

21) A customer at a store bought 3 bottles of juice and 6 fruit pies for a total cost of \$57.75. If a bottle of juice costs \$3.25, find the cost of a fruit pie.

22) A customer at a store bought 6 bottles of juice and 5 fruit pies for a total cost of \$63.00. If a bottle of juice costs \$4.25, find the cost of a fruit pie.

23) The linear equation in two variables  $y = 0.10x + 175$  models the total weekly cost,  $y$ , in dollars, for renting a car and driving it  $x$  miles. The equation indicates that the rental company charges a fixed amount of \$175 for the week plus a cost of \$0.10 for each mile the car is driven. Find a solution of  $y = 0.10x + 175$  using 205 for  $x$ .

24) The linear equation in two variables  $y = 0.10x + 150$  models the total weekly cost,  $y$ , in dollars, for renting a car and driving it  $x$  miles. The equation indicates that the rental company charges a fixed amount of \$150 for the week plus a cost of \$0.10 for each mile the car is driven. Find a solution of  $y = 0.10x + 150$  using 180 for  $x$ .

Graph the linear equation using the slope and y-intercept.

25)  $y = -2x - 4$

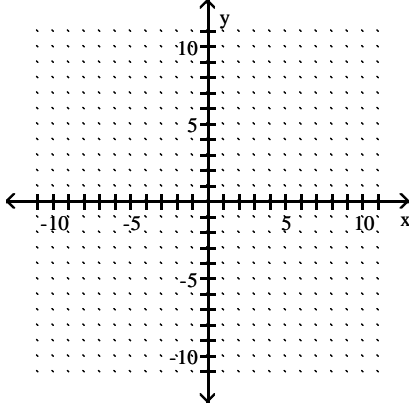

28)  $y = \frac{3}{4}x + 3$

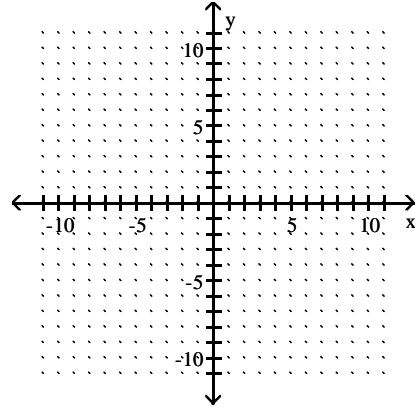

26)  $y = -5x + 4$

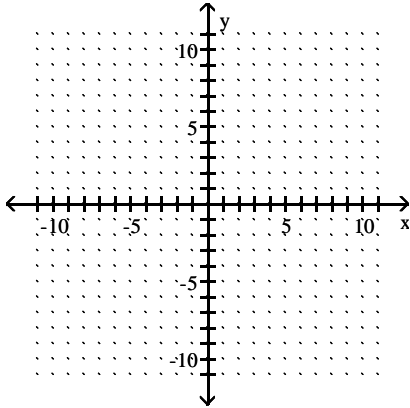

29)  $y = -\frac{5}{4}x$

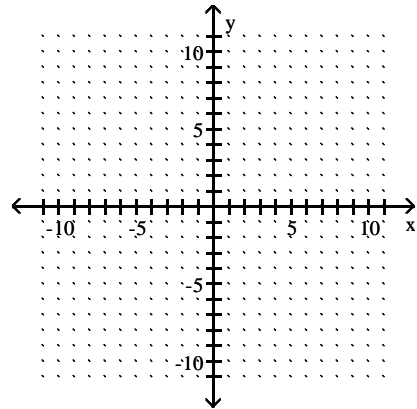

27)  $y = \frac{4}{5}x - 4$

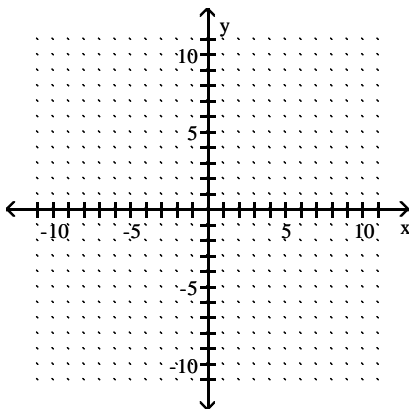

30)  $y = 2x$

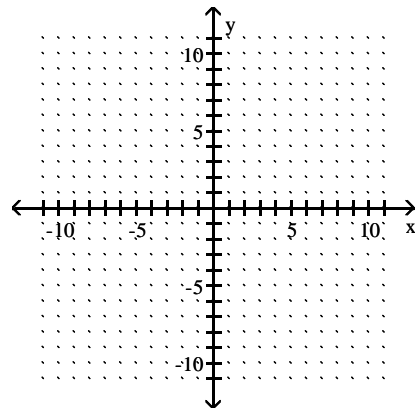

Graph the equation.

31)  $y = -2$

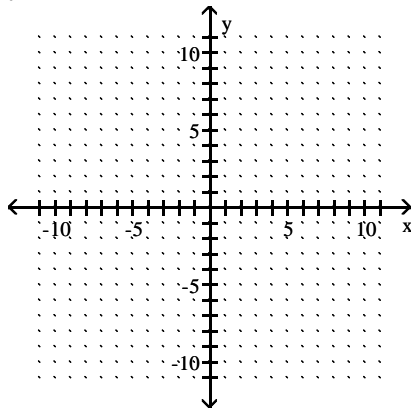

34)  $y + 3 = 0$

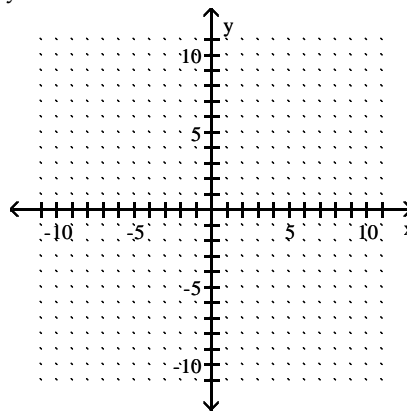

32)  $x = 2$

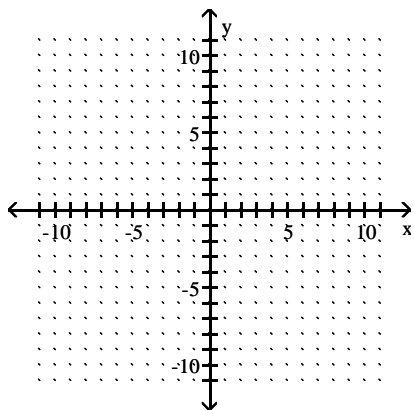

35)  $x + 3 = 0$

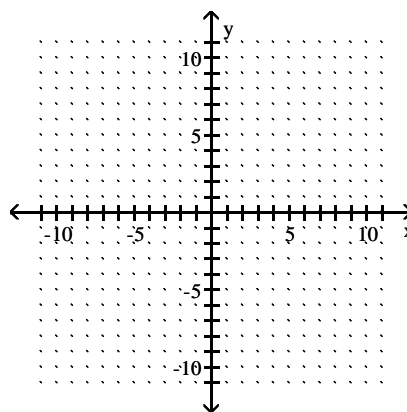

33)  $y + 2 = 0$

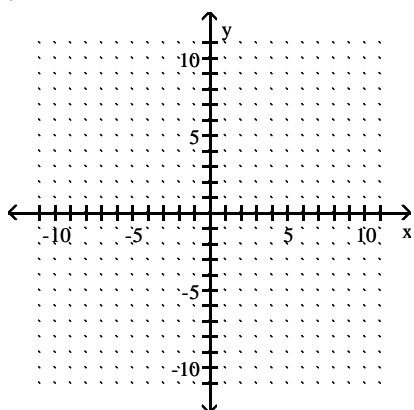

36)  $x + 2 = 0$

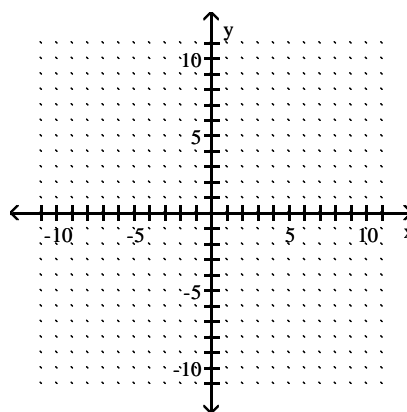

37)  $x = 3$

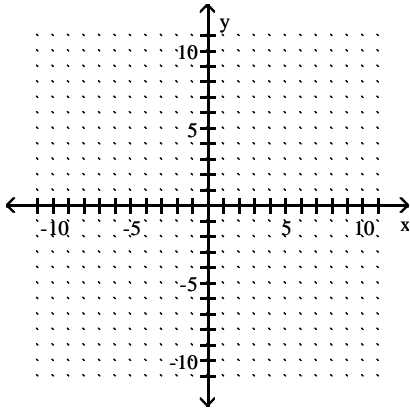

Write an equation for the graph.

40)

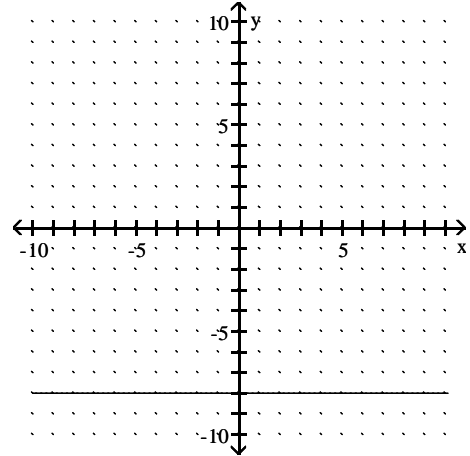

38)  $y = -6$

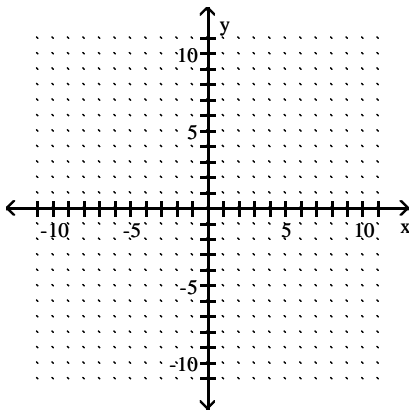

41)

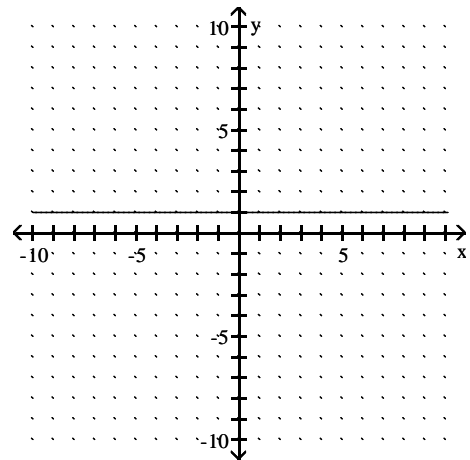

39)  $y = 3$

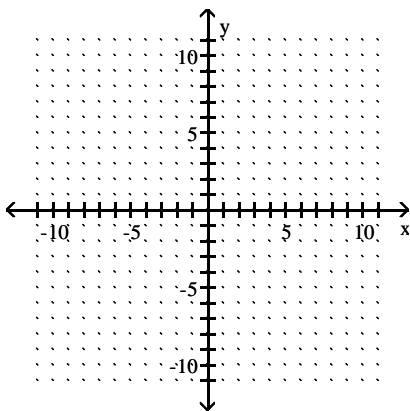

42)

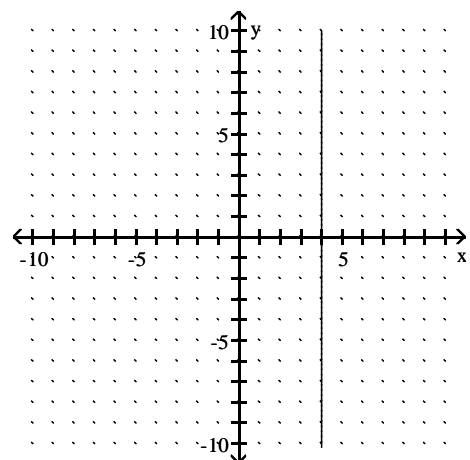

**Find the slope of the line passing through the pair of points or state that the slope is undefined.**

43)  $(-5, -9)$  and  $(-5, 6)$

44)  $(-8, 1)$  and  $(-8, 8)$

45)  $(3, -6)$  and  $(3, -2)$

46)  $(6, 7)$  and  $(-5, 7)$

47)  $(-5, -3)$  and  $(4, -3)$

48)  $(8, 9)$  and  $(3, 9)$

**Find the slope of the line.**

49)  $y = 8 - x$

50)  $y = 10 - x$

51)  $4x + y = 7$

52)  $8x + y = 46$

53)  $5x - 2y = -19$

54)  $2x + 5y = 30$

55)  $4x - 2y = 18$

**Find the y-intercept.**

56)  $y = -7x$

57)  $y = 4x$

58)  $y = 5x$

59)  $y = -2$

60)  $y = -6$

61)  $-4x + y = -1$

62)  $-2x + y = -7$

63)  $8x + y = 0$

64)  $4x + y = 0$

**Find the slope of the line.**

65)  $y = -5x - 1$

66)  $y = -\frac{3}{7}x + 3$

67)  $6x + y = -33$

68)  $3x + 7y = -29$

**Find the point-slope form of the equation of the line satisfying the given conditions and use this to write the slope-intercept form of the equation.**

69) Slope = 7, passing through (2, 4)

70) Slope = 3, passing through (2, 2)

71) Passing through (2, -11), (-11, 2)

72) Passing through (5, 4), (4, 5)

73) Passing through (0, 5) and (-3, 3)

74) Passing through (6, -17) and (3, -12)

75) x-intercept =  $\frac{5}{2}$  and y-intercept = 2

76) x-intercept =  $\frac{5}{2}$  and y-intercept = 3

77) x-intercept =  $\frac{5}{2}$  and y-intercept = 5

78) x-intercept = -6 and y-intercept = 3

79) x-intercept = 5 and y-intercept = 4

**Write an equation in slope-intercept form of the line satisfying the given conditions.**

80) Parallel to the line  $y = -4x - 1$ ; containing the point (2, 6)

81) Parallel to the line  $y = 5x - 4$ ; containing the point (1, 4).

82) Parallel to the line  $5x + 3y = 54$ ; containing the point (9, -4).

83) Perpendicular to the line  $x + 5y = -5$ ; containing the point (-4, 4).

**Determine if the ordered pair satisfies the inequality.**

84)  $x + y > 6$ : (2, 5)

85)  $y > -x + 7$ : (-4, 12)

86)  $y > -x - 7$ : (1, -7)

87)  $x \leq y + 8$ : (-1, -11)

88)  $x \leq y + 2$ : (-2, -6)

89)  $x + y > 4$ : (-1, 6)

90)  $x - y \leq -3$ : (-2, 2)

91)  $x - y \leq -3$ : (-3, 2)

92)  $x - y \leq -5$ :  $(-3, 1)$

93)  $x - y \leq 4$ :  $(5, -2)$

94)  $2x + 3y \leq 6$ :  $(3, 1)$

95)  $2x + 3y \leq -6$ :  $(3, 5)$

98)  $x + y < -4$

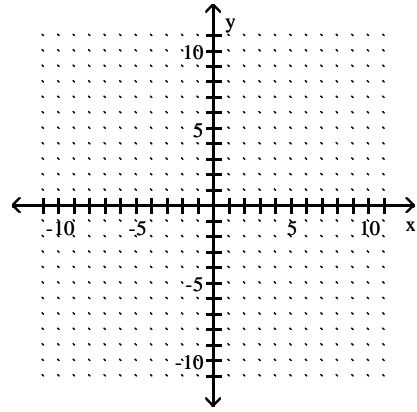

**Graph the inequality.**

96)  $x - y > -3$

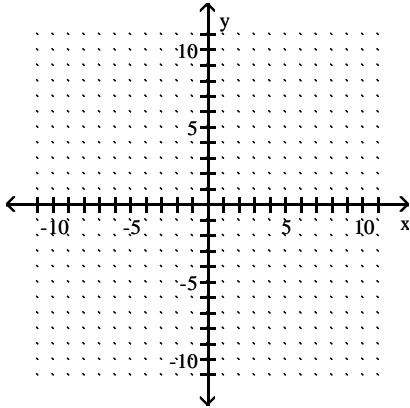

99)  $x + y \leq 2$

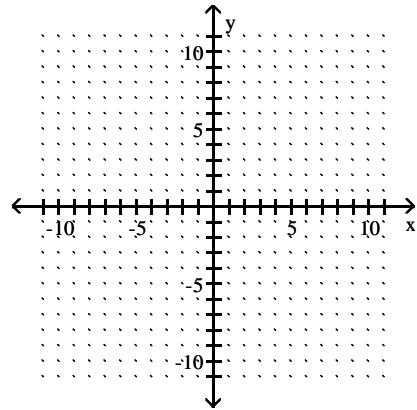

97)  $x + y < -2$

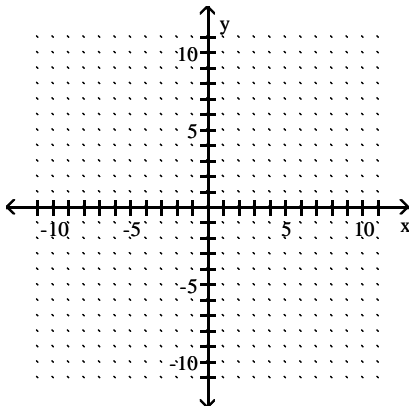

100)  $4x + y \leq -1$

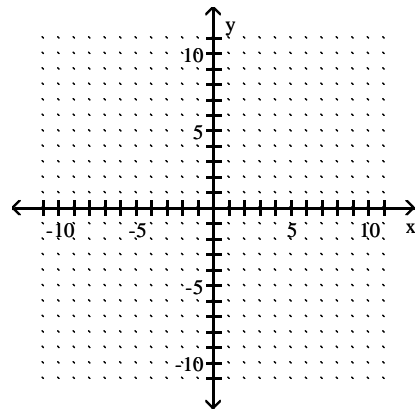

101)  $x + 4y \geq -4$

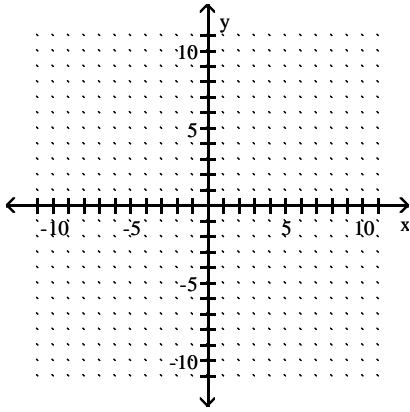

104)  $-2x - 3y \leq 6$

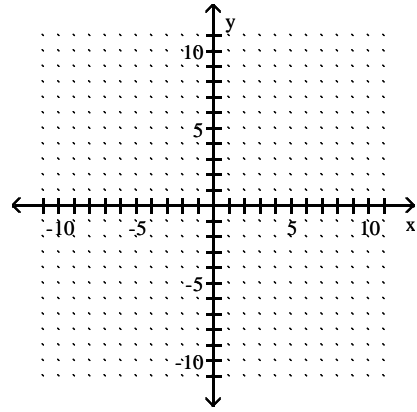

102)  $-3x + y \leq 6$

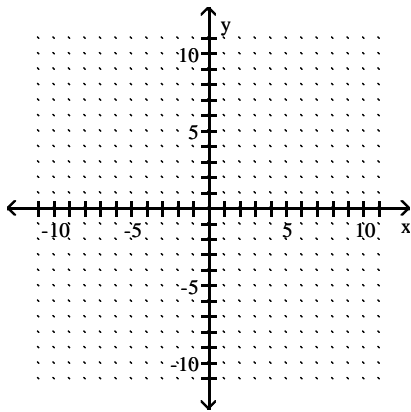

105)  $2x + 4y \geq -8$

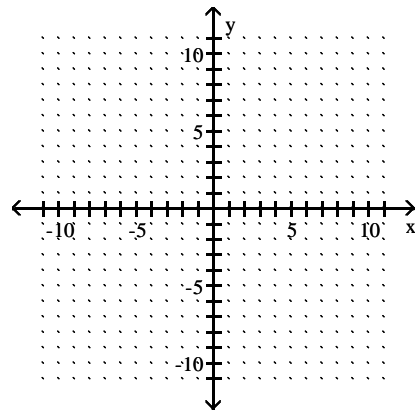

103)  $2x + 3y \leq 6$

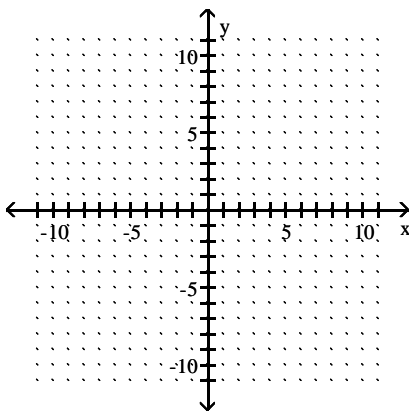

106)  $y \geq -3x$

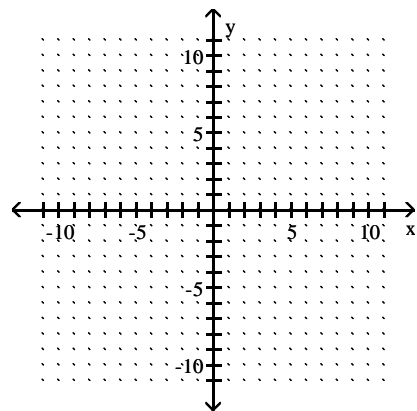

107)  $y < \frac{2}{5}x$

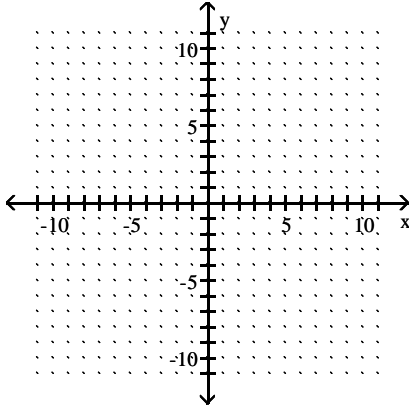

110)  $y \leq -1$

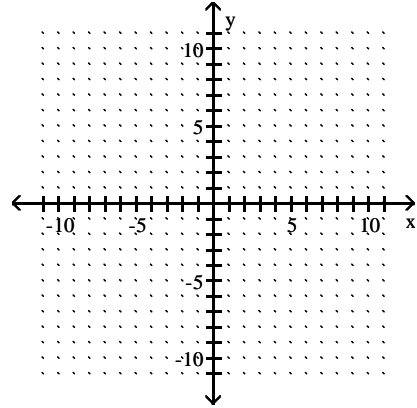

108)  $y \leq 5x - 2$

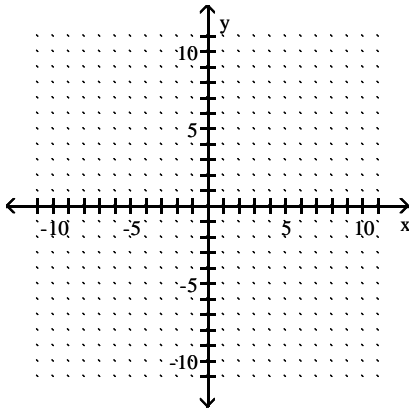

109)  $x > 6$

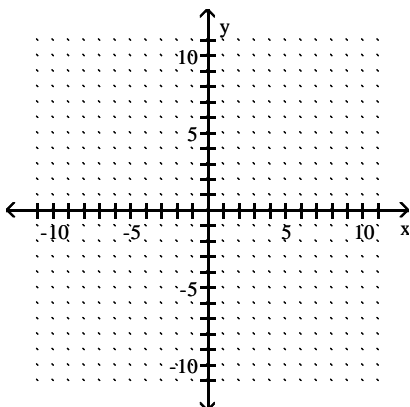

**Solve.**

111) A woman works out by running and swimming. When she runs, she burns 9 calories per minute. When she swims, she burns 8 calories per minute. She wants to burn at least 360 calories in her workout. These data are summarized by the linear inequality  $9x + 8y \geq 360$ . Graph an inequality that describes when  $x$  minutes running and  $y$  minutes swimming will burn at least as many calories as the woman wants to burn.

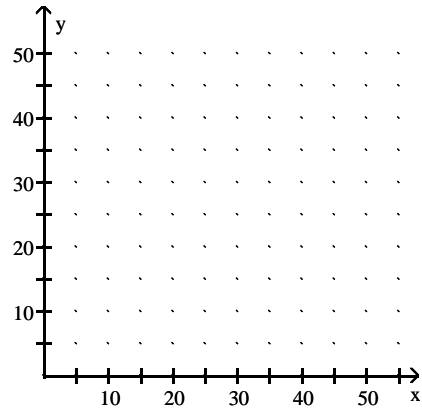

# Answer Key

Testname: E02PREP\_3.3TO3.6V012

1)  $G = (5, 4), H = (-3, -6)$

2)  $C = (-3, 2), D = (2, -5)$

3)  $G = (2, -4), H = (-7, 3)$

4) Yes

5) No

6) Yes

7) No

8) Yes

9) No

10)

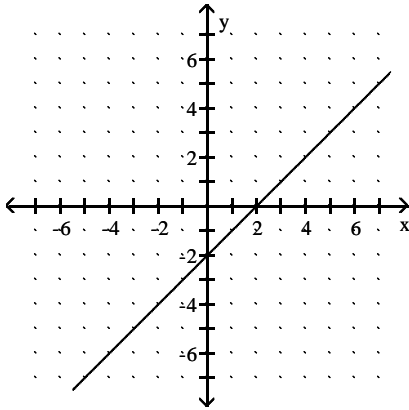

11)  $(-3, -1)$

12)  $(4, -31)$

13)  $(2, 8)$

14)  $(4, 21)$

15)  $(-3, -24)$

16)  $(-4, -12)$

17)  $(6, 26)$

18)  $(0, 3)$

19)  $8x + 6y = 73.00$

20)  $4x + 8y = 79.00$

21) \$8.00

22) \$7.50

23)  $(205, 195.5)$

24)  $(180, 168)$

25)

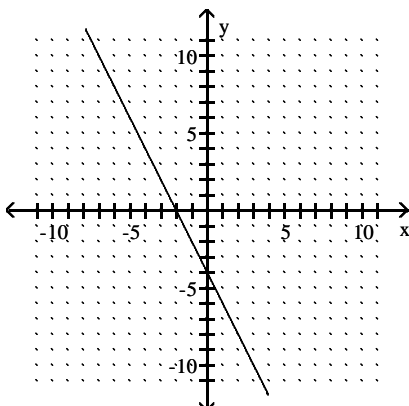

Answer Key

Testname: E02PREP\_3.3TO3.6V012

26)

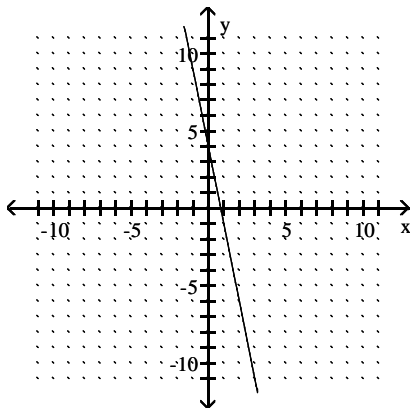

27)

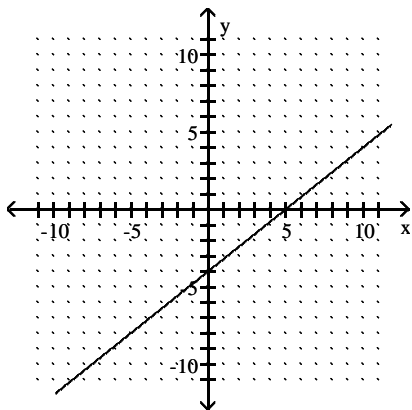

28)

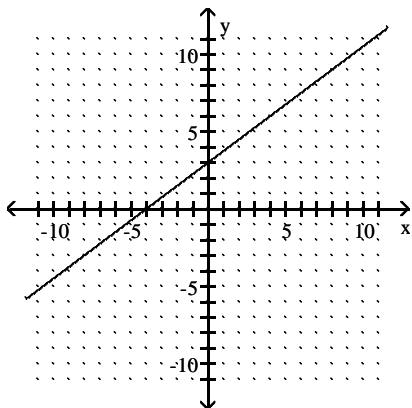

Answer Key

Testname: E02PREP\_3.3TO3.6V012

29)

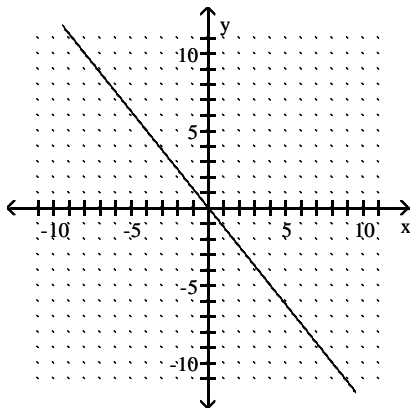

30)

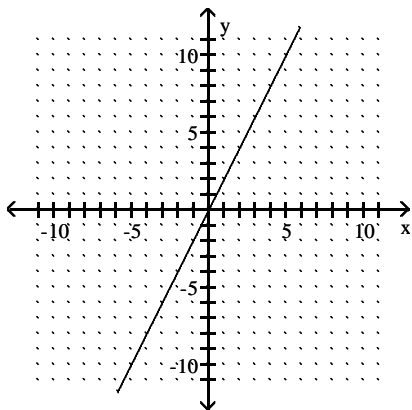

31)

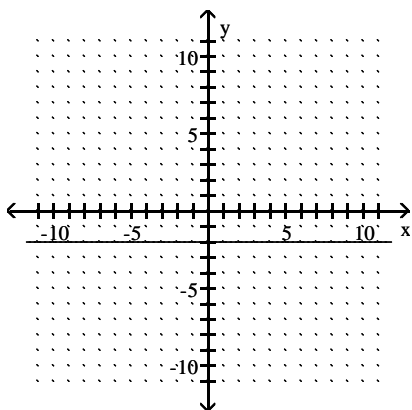

Answer Key

Testname: E02PREP\_3.3TO3.6V012

32)

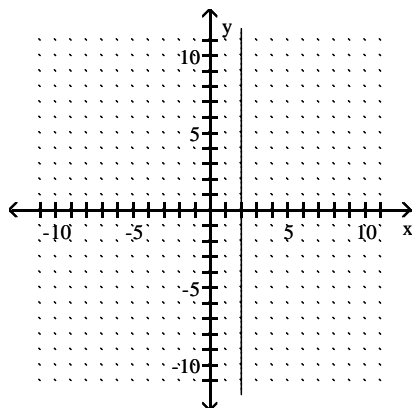

33)

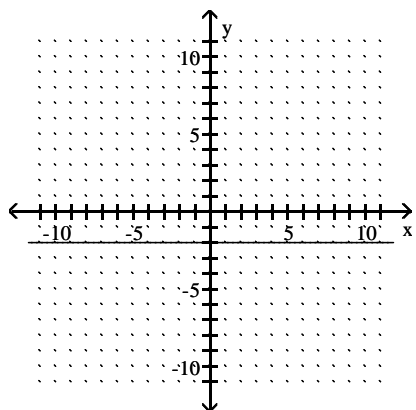

34)

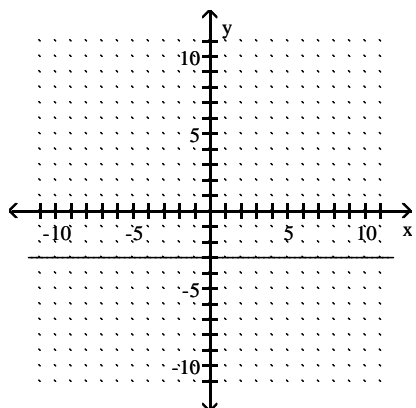

Answer Key

Testname: E02PREP\_3.3TO3.6V012

35)

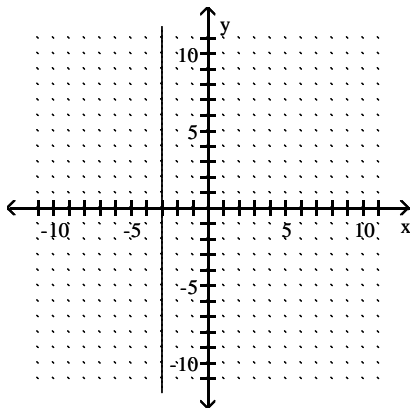

36)

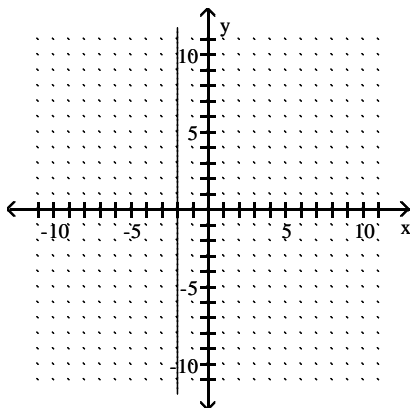

37)

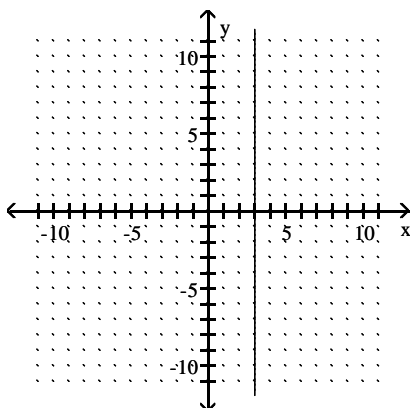

Answer Key

Testname: E02PREP\_3.3TO3.6V012

38)

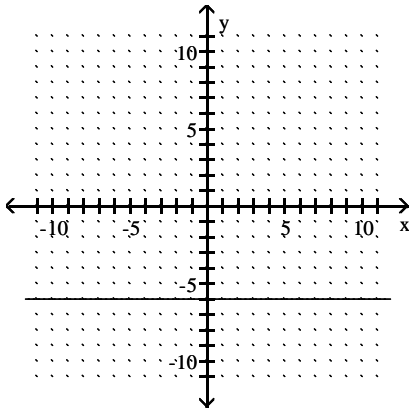

39)

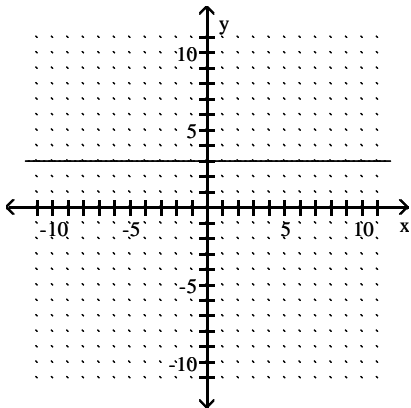

40)  $y = -8$

41)  $y = 1$

42)  $x = 4$

43) undefined

44) undefined

45) undefined

46) 0

47) 0

48) 0

49) -1

50) -1

51) -4

52) -8

53)  $\frac{5}{2}$

54)  $-\frac{2}{5}$

55) 2

56) 0

57) 0

58) 0

59) -2

60) -6

## Answer Key

Testname: E02PREP\_3.3TO3.6V012

61) - 1

62) - 7

63) 0

64) 0

65) - 5

66)  $-\frac{3}{7}$

67) - 6

68)  $-\frac{3}{7}$

69)  $y = 7x - 10$

70)  $y = 3x - 4$

71)  $y = -x - 9$

72)  $y = -x + 9$

73)  $y = \frac{2}{3}x + 5$

74)  $y = -\frac{5}{3}x - 7$

75)  $y = -\frac{4}{5}x + 2$

76)  $y = -\frac{6}{5}x + 3$

77)  $y = -2x + 5$

78)  $y = \frac{1}{2}x + 3$

79)  $y = -\frac{4}{5}x + 4$

80)  $y = -4x + 14$

81)  $y = 5x - 1$

82)  $y = -\frac{5}{3}x + 11$

83)  $y = 5x + 24$

84) Yes

85) Yes

86) Yes

87) No

88) No

89) Yes

90) Yes

91) Yes

92) No

93) No

94) No

95) No

Answer Key

Testname: E02PREP\_3.3TO3.6V012

96)

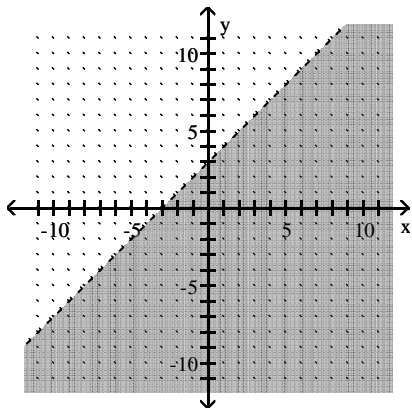

97)

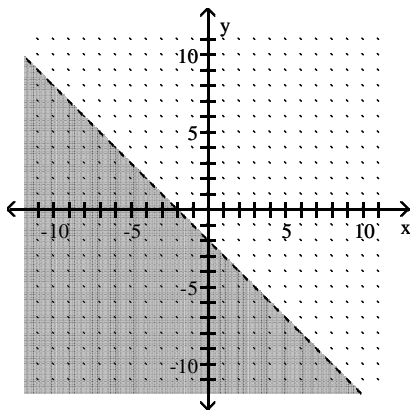

98)

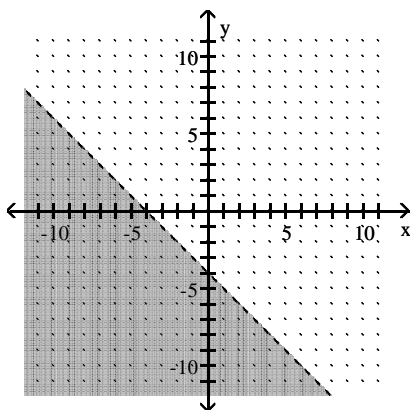

Answer Key

Testname: E02PREP\_3.3TO3.6V012

99)

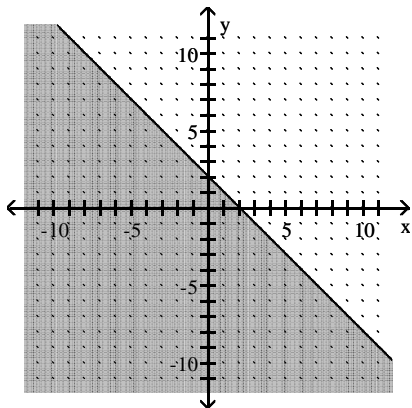

100)

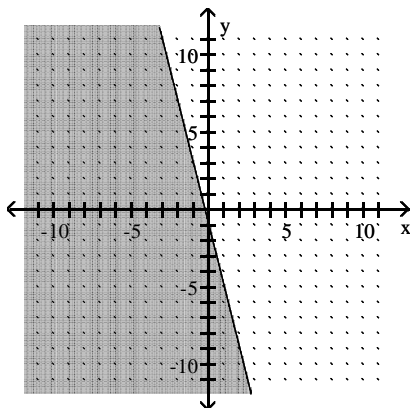

101)

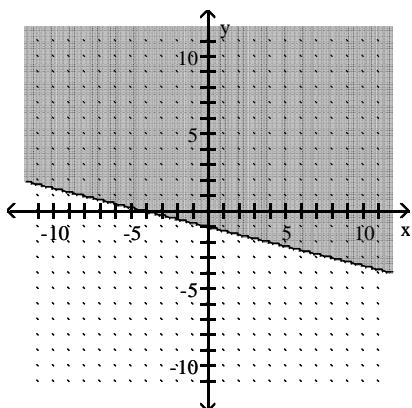

Answer Key

Testname: E02PREP\_3.3TO3.6V012

102)

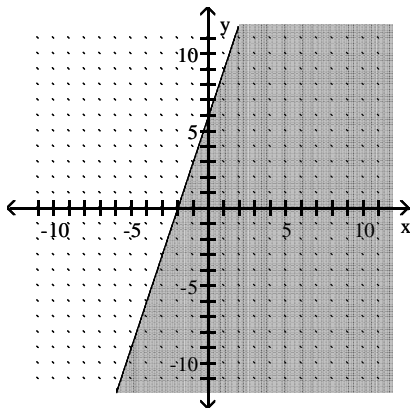

103)

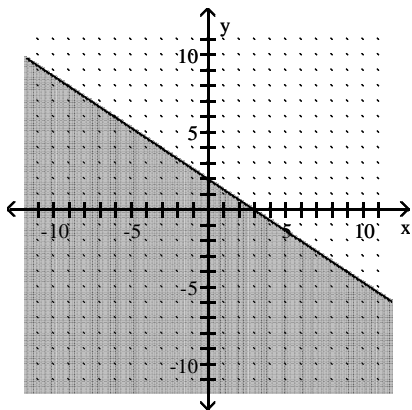

104)

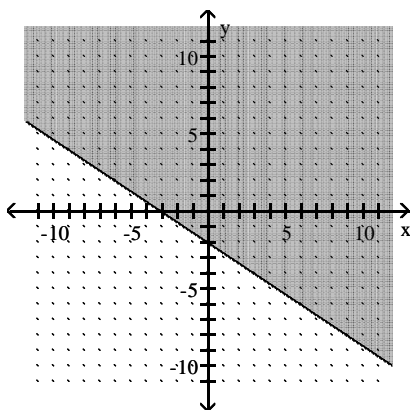

Answer Key

Testname: E02PREP\_3.3TO3.6V012

105)

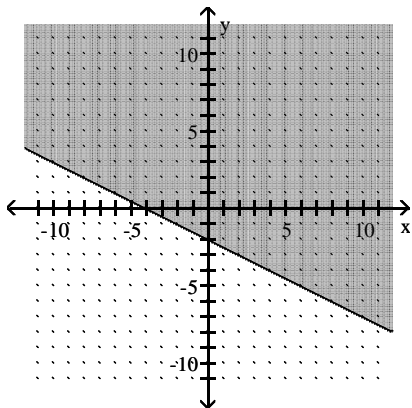

106)

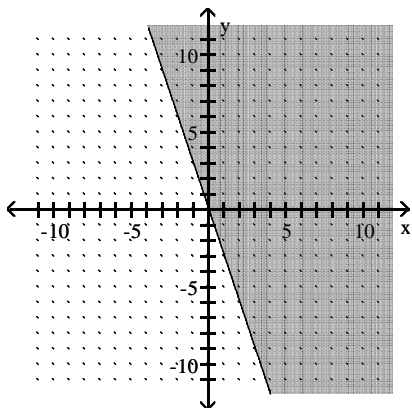

107)

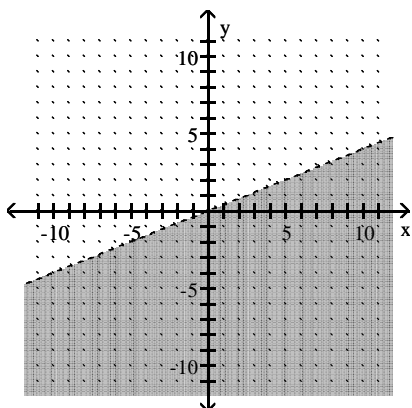

Answer Key

Testname: E02PREP\_3.3TO3.6V012

108)

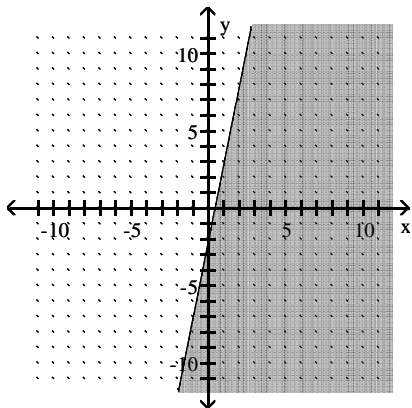

109)

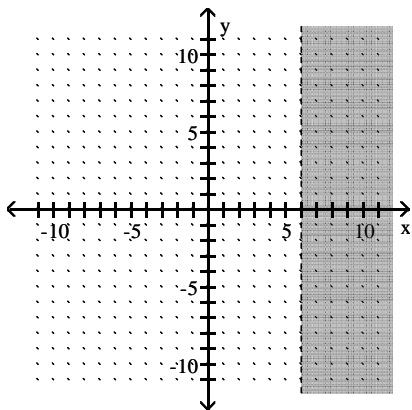

110)

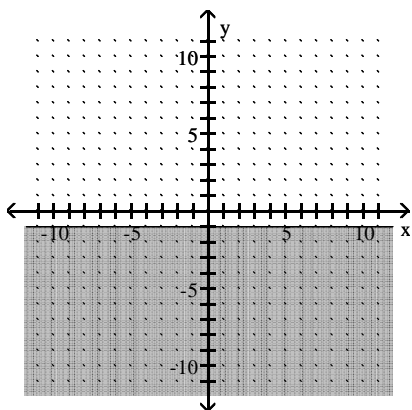

Answer Key

Testname: E02PREP\_3.3TO3.6V012

111)

