

Name \_\_\_\_\_

Determine whether the ordered pair is a solution of the system.

1)  $(-4, -5)$   

$$\begin{cases} x + y = -9 \\ x - y = 1 \end{cases}$$

2)  $(1, -1)$   

$$\begin{cases} x + y = 0 \\ x - y = 2 \end{cases}$$

3)  $(-6, -3)$   

$$\begin{cases} 2x + y = -15 \\ 4x + 2y = -30 \end{cases}$$

4)  $(6, -5)$   

$$\begin{cases} 4x + y = 19 \\ 3x + 4y = -2 \end{cases}$$

5)  $(2, 3)$   

$$\begin{cases} x + y = 5 \\ x - y = -1 \end{cases}$$

6)  $(3, -5)$   

$$\begin{cases} x + y = -8 \\ x - y = 2 \end{cases}$$

7)  $(-1, -2)$   

$$\begin{cases} x + y = -1 \\ x - y = 3 \end{cases}$$

8)  $(2, -1)$   

$$\begin{cases} x + y = -3 \\ x - y = -1 \end{cases}$$

Solve the system by graphing. If there is no solution or an infinite number of solutions, so state. Use set notation to express the solution set.

9) 
$$\begin{cases} y - 6x = 2 \\ 2y = 12x + 4 \end{cases}$$

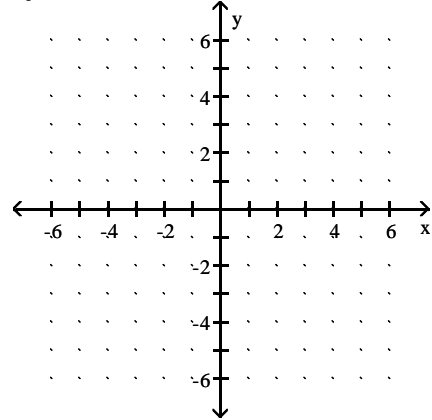

10) 
$$\begin{cases} y - 4x = 5 \\ 5y = 20x + 25 \end{cases}$$

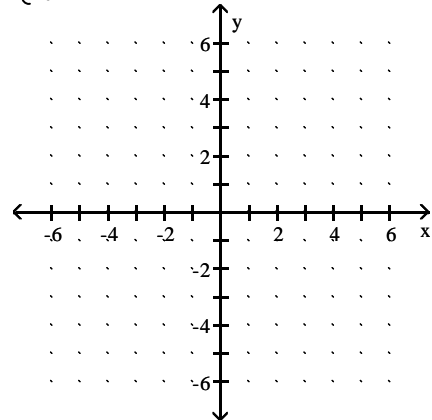

$$11) \begin{cases} y - 2x = 3 \\ 6y = 12x + 18 \end{cases}$$

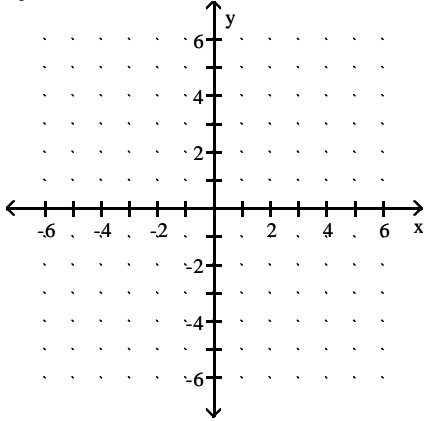

$$14) \begin{cases} 3x + y = 12 \\ 12x + 4y = 48 \end{cases}$$

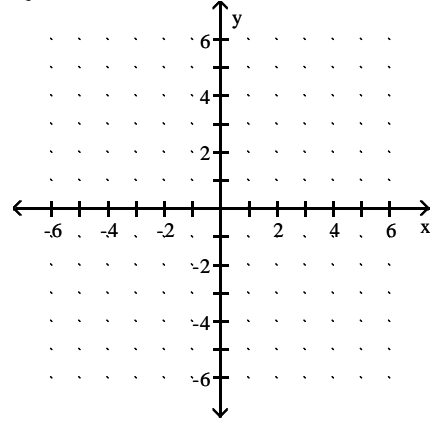

$$12) \begin{cases} x = -y \\ y + x = 6 \end{cases}$$

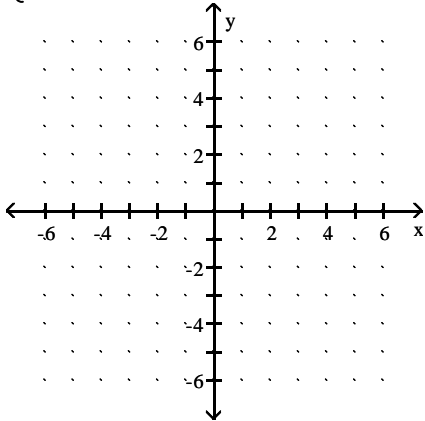

$$15) \begin{cases} x = -y \\ y + x = 6 \end{cases}$$

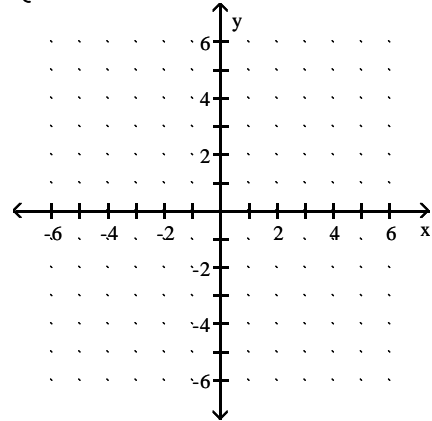

$$13) \begin{cases} 4x + y = 16 \\ 12x + 3y = 48 \end{cases}$$

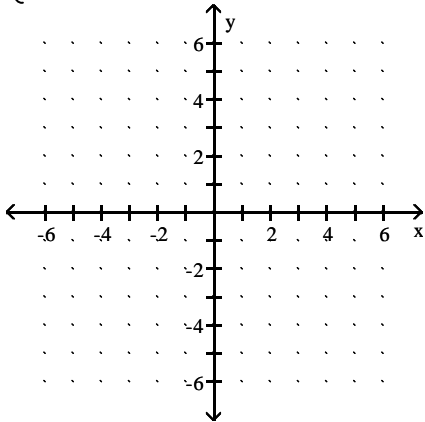

$$16) \begin{cases} 4x + y = 14 \\ 16x + 4y = 56 \end{cases}$$

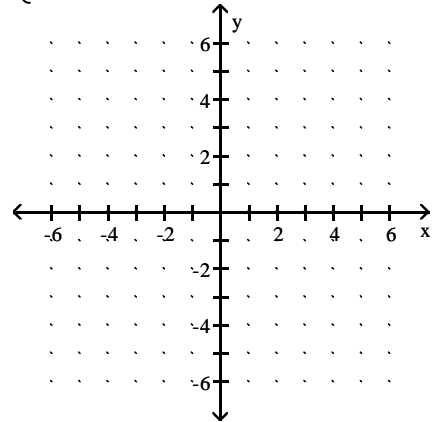

Solve the system by the substitution method. If there is no solution or an infinite number of solutions, so state. Use set notation to express the solution set.

$$17) \begin{cases} x + y = 4 \\ y = 3x \end{cases}$$

$$18) \begin{cases} x + y = 9 \\ y = 2x \end{cases}$$

$$19) \begin{cases} 8x - 4y = -16 \\ 3x + 2y = -6 \end{cases}$$

$$20) \begin{cases} 9x + 8y = -54 \\ -7x + 5y = 42 \end{cases}$$

$$21) \begin{cases} x - 4 = y \\ y + 8 = x \end{cases}$$

Solve the system by the addition method. If there is no solution or an infinite number of solutions, so state. Use set notation to express the solution set.

$$22) \begin{cases} x + y = 3 \\ x - y = 13 \end{cases}$$

$$23) \begin{cases} x + y = 6 \\ x - y = 10 \end{cases}$$

$$24) \begin{cases} x - 5y = -8 \\ 7x - 5y = -26 \end{cases}$$

$$25) \begin{cases} x + 3y = 0 \\ -4x + 3y = 30 \end{cases}$$

Solve the system by the best method. Use set notation to express the solution set.

$$26) \begin{cases} 4x + 9y = 7 \\ 4x + 9y = 13 \end{cases}$$

$$27) \begin{cases} 3x + 9y = 4 \\ 3x + 9y = 12 \end{cases}$$

$$28) \begin{cases} 6x + 8y = 7 \\ 6x + 8y = 14 \end{cases}$$

$$29) \begin{cases} 5x + 3y = 9 \\ 5x + 3y = 8 \end{cases}$$

$$30) \begin{cases} -5x = -30 \\ x - 5y = 21 \end{cases}$$

$$31) \begin{cases} 5x = 25 \\ x - 9y = 23 \end{cases}$$

$$32) \begin{cases} 8x + 14 = 6y \\ 5x - 2y = -14 \end{cases}$$

$$33) \begin{cases} 8x - 12 = 5y \\ 5x - 2y = 3 \end{cases}$$

$$34) \begin{cases} 7x + 9y = 2 \\ 7x + 9y = 16 \end{cases}$$

$$35) \begin{cases} 5x + 7y = 6 \\ 5x + 7y = 12 \end{cases}$$

**Solve the problem.**

36) Jamil always throws loose change into a pencil holder on his desk and takes it out every two weeks. This time it is all nickels and dimes. There are 5 times as many dimes as nickels, and the value of the dimes is \$1.35 more than the value of the nickels. How many nickels and dimes does Jamil have?

37) Jamil always throws loose change into a pencil holder on his desk and takes it out every two weeks. This time it is all nickels and dimes. There are 9 times as many dimes as nickels, and the value of the dimes is \$10.20 more than the value of the nickels. How many nickels and dimes does Jamil have?

38) Jamil always throws loose change into a pencil holder on his desk and takes it out every two weeks. This time it is all nickels and dimes. There are 7 times as many dimes as nickels, and the value of the dimes is \$3.25 more than the value of the nickels. How many nickels and dimes does Jamil have?

39) Yvette has up to \$3000 to invest and has chosen to put her money into telecommunications and pharmaceuticals. The telecommunications investment is to be no more than 3 times the pharmaceuticals investment. Write a system of inequalities to describe the situation. Let  $x$  = amount to be invested in telecommunications and  $y$  = amount to be invested in pharmaceuticals.

40) Yvette has up to \$2000 to invest and has chosen to put her money into telecommunications and pharmaceuticals. The telecommunications investment is to be no more than 2 times the pharmaceuticals investment. Write a system of inequalities to describe the situation. Let  $x$  = amount to be invested in telecommunications and  $y$  = amount to be invested in pharmaceuticals.

41) Yvette has up to \$4000 to invest and has chosen to put her money into telecommunications and pharmaceuticals. The telecommunications investment is to be no more than 5 times the pharmaceuticals investment. Write a system of inequalities to describe the situation. Let  $x$  = amount to be invested in telecommunications and  $y$  = amount to be invested in pharmaceuticals.

**Solve.**

42) A bank loaned out \$64,000, part of it at the rate of 10% per year and the rest at a rate of 6% per year. If the interest received was \$4880, how much was loaned at 10%?

43) A bank loaned out \$64,000, part of it at the rate of 9% per year and the rest at a rate of 4% per year. If the interest received was \$3960, how much was loaned at 9%?

44) A bank loaned out \$56,000, part of it at the rate of 9% per year and the rest at a rate of 5% per year. If the interest received was \$4080, how much was loaned at 9%?

45) A bank loaned out \$54,000, part of it at the rate of 9% per year and the rest at a rate of 5% per year. If the interest received was \$4060, how much was loaned at 9%?

Graph the solution set of the system of linear inequalities.  
If the system has no solutions, state this.

$$46) \begin{cases} x + y > 5 \\ x - y \leq 4 \end{cases}$$

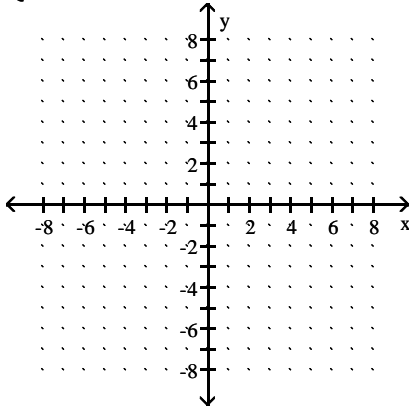

$$49) \begin{cases} x + y > -4 \\ x - y \leq 1 \end{cases}$$

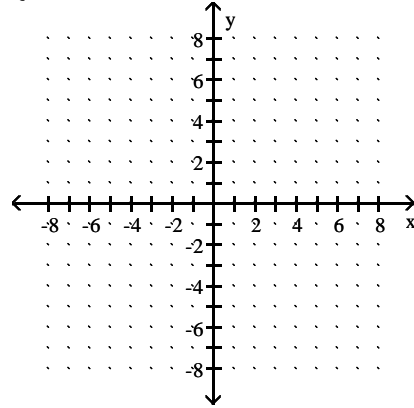

$$47) \begin{cases} x + y > 5 \\ x - y \leq 3 \end{cases}$$

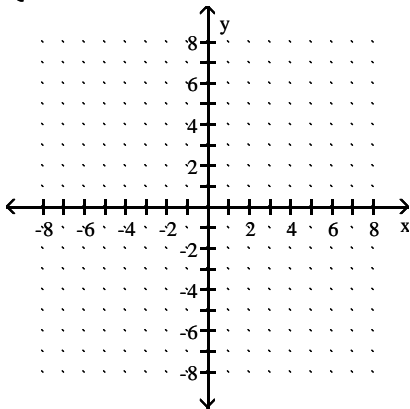

$$50) \begin{cases} 2x + y \geq 4 \\ x > 1 \end{cases}$$

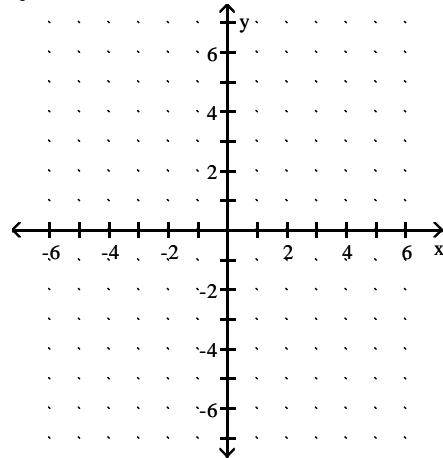

$$48) \begin{cases} x + y > 2 \\ x - y \leq -5 \end{cases}$$

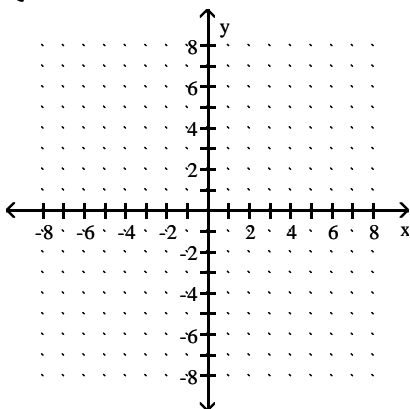

$$51) \begin{cases} x + y > -4 \\ x - y \leq -5 \end{cases}$$

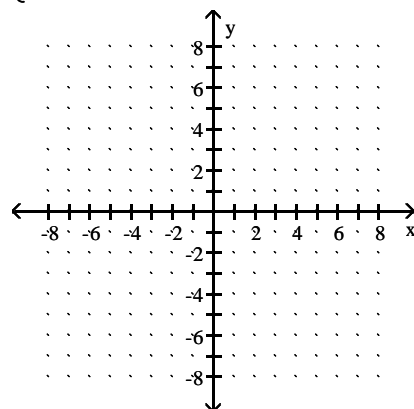

Use the order of operations to simplify the expression.

52)  $21 - [9 - (4 - 9)] + (4 - 6)^3$

53)  $25 - [7 - (6 - 9)] + (2 - 4)^3$

54)  $23 - [6 - (5 - 12)] + (3 - 5)^3$

Solve the equation.

55)  $\frac{1}{4}x - \frac{3}{8}x = 5$

56)  $\frac{1}{4}x - \frac{3}{8}x = 4$

57)  $\frac{1}{4}x - \frac{3}{8}x = 2$

58)  $\frac{3}{2} + \frac{x}{3} = \frac{17}{6}$

59)  $\frac{4}{3} + \frac{x}{2} = \frac{23}{6}$

60)  $\frac{4}{5} - \frac{x}{3} = \frac{14}{15}$

61)  $\frac{1}{4}x - \frac{3}{8}x = 3$

62)  $\frac{5}{4} + \frac{x}{3} = \frac{5}{12}$

Find the volume of the figure. Where applicable, express answers in terms of  $\pi$ .

63)

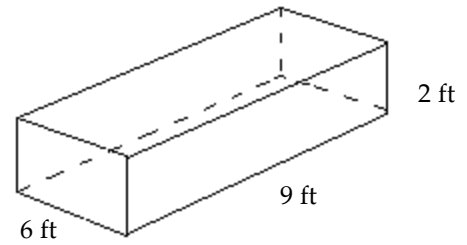

64)

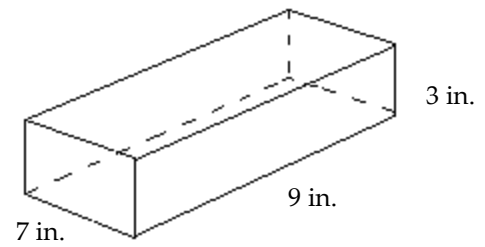

65)

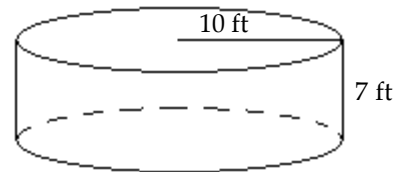

66)

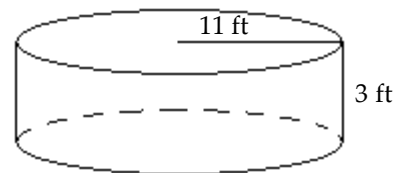

Find the slope of the line passing through the pair of points or state that the slope is undefined.

67)  $(-5, -7)$  and  $(2, -2)$

68)  $(-1, 9)$  and  $(6, -4)$

69)  $(3, 6)$  and  $(-7, -9)$

70)  $(13, 1)$  and  $(3, 14)$

71)  $(16, -13)$  and  $(12, -18)$

72)  $(-11, 7)$  and  $(-3, 10)$

Find the point-slope form of the equation of the line satisfying the given conditions and use this to write the slope-intercept form of the equation.

73) Slope = 5, passing through  $(2, 5)$

74) Slope = 6, passing through  $(3, 5)$

75) Slope = -3, passing through  $(2, 4)$

76) Slope = -2, passing through  $(4, 3)$

Find the slope of the line, or state that the slope is undefined.

77)

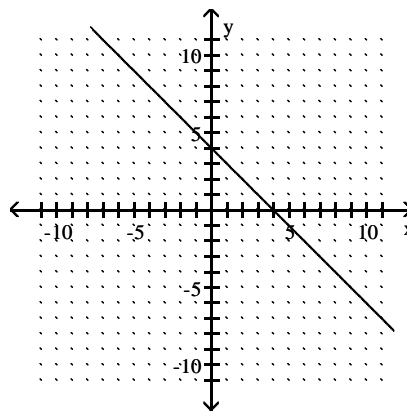

78)

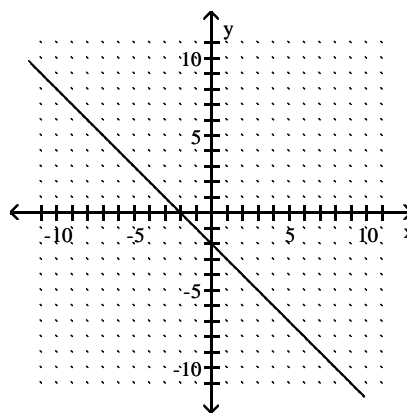

79)

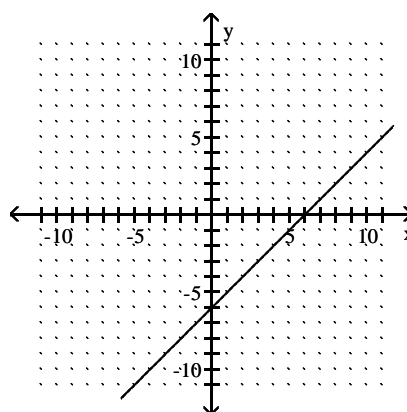

80)

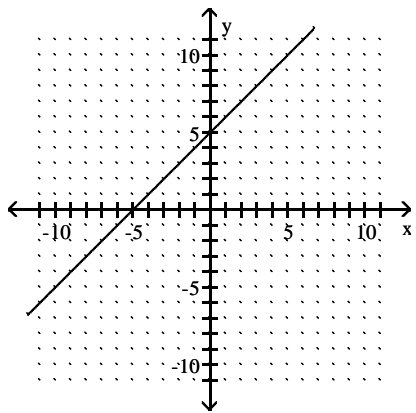

83)

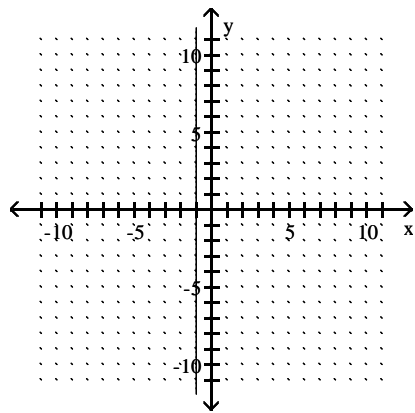

81)

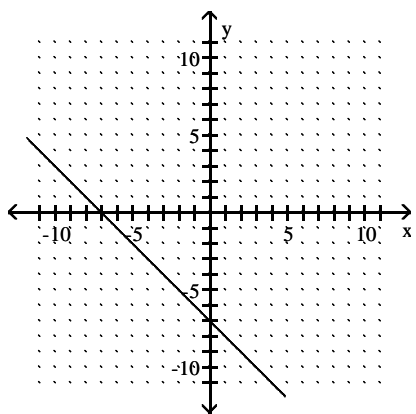

84)

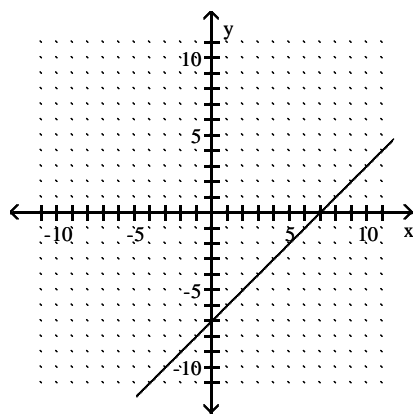

82)

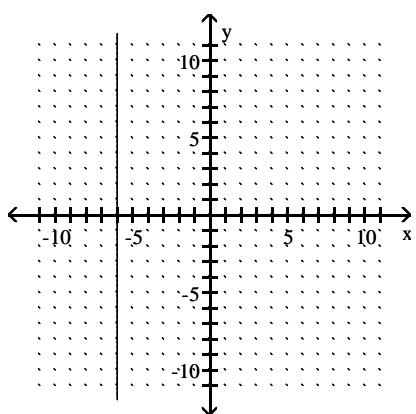

85)

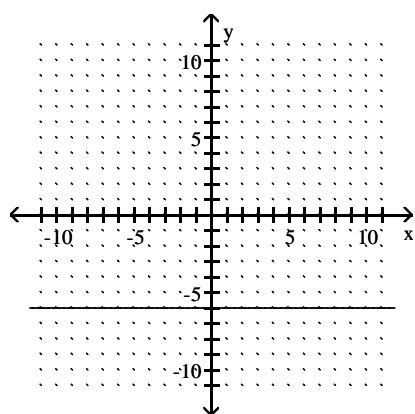

## Answer Key

Testname: E03PREP\_CH4\_ETAL\_V02

- 1) Yes
- 2) Yes
- 3) Yes
- 4) Yes
- 5) Yes
- 6) No
- 7) No
- 8) No
- 9) infinitely many solutions;  $\{(x, y) \mid y - 6x = 2\}$  or  $\{(x, y) \mid 2y = 12x + 4\}$
- 10) infinitely many solutions;  $\{(x, y) \mid y - 4x = 5\}$  or  $\{(x, y) \mid 5y = 20x + 25\}$
- 11) infinitely many solutions;  $\{(x, y) \mid y - 2x = 3\}$  or  $\{(x, y) \mid 6y = 12x + 18\}$
- 12) no solution;  $\emptyset$
- 13) infinitely many solutions;  $\{(x, y) \mid 4x + y = 16\}$  or  $\{(x, y) \mid 12x + 3y = 48\}$
- 14) infinitely many solutions;  $\{(x, y) \mid 3x + y = 12\}$  or  $\{(x, y) \mid 12x + 4y = 48\}$
- 15) no solution;  $\emptyset$
- 16) infinitely many solutions;  $\{(x, y) \mid 4x + y = 14\}$  or  $\{(x, y) \mid 16x + 4y = 56\}$
- 17)  $\{(1, 3)\}$
- 18)  $\{(3, 6)\}$
- 19)  $\{(-2, 0)\}$
- 20)  $\{(-6, 0)\}$
- 21) no solution;  $\emptyset$
- 22)  $\{(8, -5)\}$
- 23)  $\{(8, -2)\}$
- 24)  $\{(-3, 1)\}$
- 25)  $\{(-6, 2)\}$
- 26) no solution;  $\emptyset$
- 27) no solution;  $\emptyset$
- 28) no solution;  $\emptyset$
- 29) no solution;  $\emptyset$
- 30)  $\{(6, -3)\}$
- 31)  $\{(5, -2)\}$
- 32)  $\{(-4, -3)\}$
- 33)  $\{(-1, -4)\}$
- 34) no solution;  $\emptyset$
- 35) no solution;  $\emptyset$
- 36) 3 nickels and 15 dimes
- 37) 12 nickels and 108 dimes
- 38) 5 nickels and 35 dimes
- 39)  $x + y \leq 3000$   
 $x \leq 3y$   
 $x \geq 0$   
 $y \geq 0$
- 40)  $x + y \leq 2000$   
 $x \leq 2y$   
 $x \geq 0$   
 $y \geq 0$
- 41)  $x + y \leq 4000$   
 $x \leq 5y$   
 $x \geq 0$   
 $y \geq 0$

Answer Key

Testname: E03PREP\_CH4\_ETAL\_V02

42) \$26,000

43) \$28,000

44) \$32,000

45) \$34,000

46)

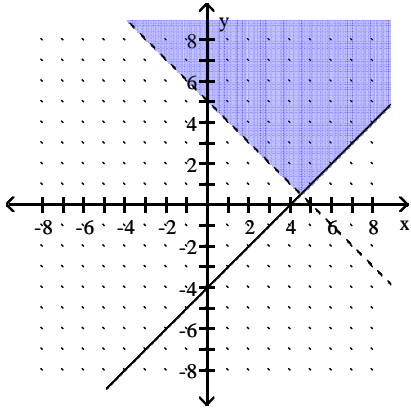

47)

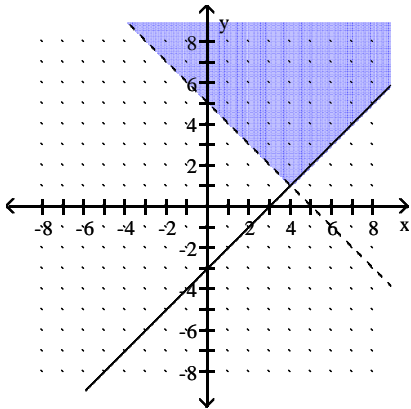

48)

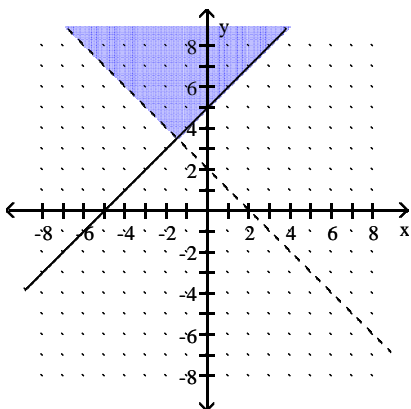

Answer Key

Testname: E03PREP\_CH4\_ETAL\_V02

49)

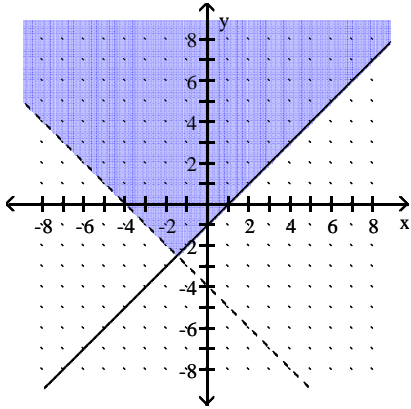

50)

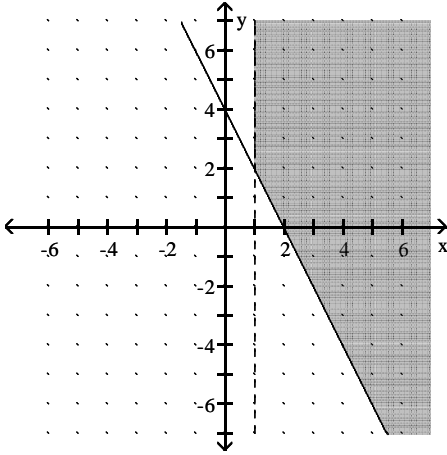

51)

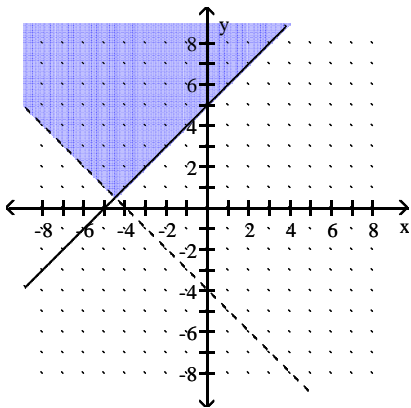

52) -1

53) 7

54) 2

55) {-40}

56) {-32}

57) {-16}

58) {4}

59) {5}

## Answer Key

Testname: E03PREP\_CH4\_ETAL\_V02

60)  $\left\{-\frac{2}{5}\right\}$

61)  $\{-24\}$

62)  $\left\{-\frac{5}{2}\right\}$

63)  $108 \text{ ft}^3$

64)  $189 \text{ in.}^3$

65)  $700\pi \text{ ft}^3$

66)  $363\pi \text{ ft}^3$

67)  $\frac{5}{7}$

68)  $-\frac{13}{7}$

69)  $\frac{3}{2}$

70)  $-\frac{13}{10}$

71)  $\frac{5}{4}$

72)  $\frac{3}{8}$

73)  $y = 5x - 5$

74)  $y = 6x - 13$

75)  $y = -3x + 10$

76)  $y = -2x + 11$

77)  $-1$

78)  $-1$

79)  $1$

80)  $1$

81)  $-1$

82) Undefined

83) Undefined

84)  $1$

85)  $0$